

■ PART I

MEMBRANES AND APPLICATIONS IN WATER AND WASTEWATER

COPYRIGHTED MATERIAL



Thin-Film Composite Membranes for Reverse Osmosis

TADAHIRO UEMURA and MASAHIRO HENMI

Global Environment Research Laboratories, Toray Industries Inc., Otsu Shiga, Japan

1.1 INTRODUCTION

Because of vastly expanding populations, increasing water demand, and the deterioration of water resource quality and quantity, water is going to be the most precious resource in the world. Thus, the 21st century is called the “water century.” In the 20th century, membrane technologies made great progress, and commercial markets have been spreading very rapidly and throughout the world. The key technologies fueling this progress are as follows:

1. *Materials*: Chemical design of high-performance materials suitable for each separation mode
2. *Morphology*: Morphological design of high-performance membranes
3. *Element/Module*: Element and module design for high-performance membranes
4. *Membrane Process*: Plant design and operation technology

In 21st century, to solve these water problems, membranes technology is going to be further expanded and new technology—further improvements of membrane performance, development of membrane systems, membranes stability such as antifouling membranes for wastewater treatment, and other highly qualified membranes—will be needed.

Among desalination technologies available today, reverse osmosis (RO) is regarded as the most economical desalination process. Therefore, RO membranes have played crucial roles in obtaining fresh water from nonconventional water resources such as seawater and wastewater.

1.2 APPLICATION OF RO MEMBRANES

Reverse osmosis membranes have been used widely for water treatment such as ultrapure water makeup, pure boiler water makeup in industrial fields, seawater and brackish water

Advanced Membrane Technology and Applications. Edited by Norman N. Li, Anthony G. Fane, W. S. Winston Ho, and T. Matsuura
Copyright © 2008 John Wiley & Sons, Inc.

TABLE 1.1 Application of Reverse Osmosis Membrane Process

Industrial Use	Drinking Water	Wastewater Treatment and Reuse
Ultrapure water, boiler water, process pure water, daily industries	Seawater desalination, brackish water desalination	Industrial water, agricultural water, indirect drinking water

desalination in drinking water production, and wastewater treatment and reuse in industrial, agricultural, and indirect drinking water production as shown in Table 1.1.

The expansion of RO membrane applications promoted the redesign of suitable membrane material to take into consideration chemical structure, membranes configuration, chemical stability, and ease of fabrication. And along with the improvements of the membranes, the applications are further developed.

1.3 MAJOR PROGRESS IN RO MEMBRANES

1.3.1 Cellulose Acetate Membrane

Reverse osmosis systems were originally presented by Reid in 1953. The first membrane, which could be used at the industrial level in actual water production plants, was a cellulose-acetate-based RO membrane invented by Loeb and Sourirajan in 1960. This membrane has a so-called asymmetric or anisotropic membrane structure having a very thin solute-rejecting active layer on a coarse supporting layer, as shown in Figure 1.1. The membrane is made from only one polymeric material, such as cellulose acetate, and made by the nonsolvent-induced phase separation method. After the invention by Loeb and Sourirajan, spiral-wound membranes elements using the cellulose acetate asymmetric flat-sheet membranes were developed and manufactured by several U.S. and Japanese companies. RO technologies have been on the market since around 1964 (Kurihara et al., 1987). They were widely used from the 1960s through the 1980s mainly for pure water makeup for industrial processes and ultrapure water production in semiconductor industries; and some are still used in some of these applications.

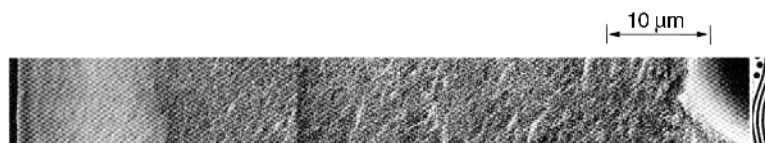

Figure 1.1 SEM photograph of CA asymmetric membrane.

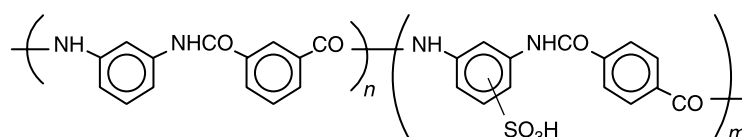

Figure 1.2 Representative chemical structure of linear polyamide membrane (B-10).

TABLE 1.2 Summary of Membrane Materials for RO

Membrane Material	Membrane Morphology	Module Configuration	Examples of Membrane and Module, Membrane Suppliers
Cellulose acetate Polyamide Heterocyclic polymer	<p>The diagram illustrates the relationship between membrane morphologies and materials. It features two boxes: 'Asymmetric membrane' and 'Composite membrane'. The 'Asymmetric membrane' box is connected to materials 1, 2, 3, 4, 5, 6, 7, and 8. The 'Composite membrane' box is connected to materials 9, 10, 11, 12, 13, and 14. Lines from these materials converge on the 'Spiral' and 'Tubular' module configurations.</p>	Spiral	<ol style="list-style-type: none"> 1. Toray, UOP, envirogenics, Osmotics, Desalination, Ajax, Hydranautics, Daiseru 2. Toray-Polyamidic acid, Du Pont-DP-1, Monsanto 3. Cellanese-Polybenzimidazole 4. UOP-CTA 5. North Star-NS-100, UOP-PA-300, -100, LP-300, RC-100 6. North Star-NS-200, Osmotics-NS-200 Envirogenics-SPFA (NS-200), Desalination-NS-200(?) 7. North Triangle Inst.-Plasma Polym. Toray-PEC-1000, Film Tec-FT-30 Asahi Glass-MVP, Nihon Syokubai 8. Dow, Monsanto, Toyobo
Cross-linked water-soluble polymer		Hollow fiber	<ol style="list-style-type: none"> 9. Du Pont 10. Cellanese-Polybenzimidazole
Polymerizable monomer (cross-linking)		Tubular	<ol style="list-style-type: none"> 11. FRL-NS-200, Gulf South Research Inst.-NS-100 12. UOP; Envirogenics, Universal Water Co. Raypak, Abcor, PCI, Nitto, Daiseru 13. Teijin-PBIL 14. North Star-NS-100, Others Sumitomo-PAN-Composite Membrane

1.3.2 Aromatic Polyamide Hollow Fiber Membrane

Since then, there has been intensive and continuous R&D efforts mainly around the United States and Japan to meet the demands from commercial markets, and there exist many inventions and breakthroughs in membrane materials and configurations to improve the performances of membranes.

To overcome the problems of cellulose acetate membranes, many synthetic polymeric materials for reverse osmosis were proposed, but except for one material, none of them proved successful. The only one material, which could remain on the market, was the linear aromatic polyamide with pendant sulfonic acid groups, as shown in Figure 1.2. This material was proposed by DuPont, which fabricated very fine hollow fiber membranes; the modules of this membrane were designated B-9 and B-10. They have a high rejection performance, which can be used for single-stage seawater desalination. They were widely used for mainly seawater or brackish water desalination and recovery of valuable materials such as electric deposition paints, until DuPont withdrew them from the market in 2001.

1.3.3 Composite Membrane

Another approach to obtain a high-performance RO membrane was investigated by some research institutes and companies in the 1970s. Many methods to prepare composite membranes have been proposed, as shown in Table 1.2. In the early stage, very thin films of a cellulose acetate (CA) polymer coating on a substrate, such as a porous cellulose nitrate substrate, was tried. However, in spite of their efforts, this approach did not succeed in industrial membranes manufacturing.

The next approach used the interfacial polycondensation reaction to form a very thin polymeric layer onto a substrate. Morgan first proposed this approach (Morgan, 1965), and then Scala et al. (1973) and Van Heuven (1976) actually applied this approach to obtain an RO membrane. But it was Cadotte who invented the high-performance membrane using the in situ interfacial condensation method (Cadotte, 1985). In his method, interfacial condensation reactions between polymeric polyamine and monomeric polyfunctional acid halides or isocyanates takes place on a substrate material to deposit a thin film barrier onto a substrate. Some of the composite membranes were succeeded in industrial fabrication by another method, which was designated as PA-300 or RC-100.

Another preparation method for composite membrane is an in situ monomer condensation method using the monomeric amine and monomeric acid halide, which was also invented by Cadotte. Then, many companies succeeded in developing composite membranes using this method, and the membrane performance has been drastically improved up to now. Now, composite membrane of cross-linked fully aromatic polyamide is regarded as the most popular and reliable material in the world. Permeate flow rate and its quality have been improved 10 times greater than that of the beginning (Kurihara et al., 1987, 1994b).

1.4 TRENDS IN RO MEMBRANE TECHNOLOGY

Figure 1.3 shows recent trends in RO membrane technology with two obvious tendencies. One is a tendency toward low-pressure membranes for operating energy reduction in the field of brackish water desalination. The other is a tendency toward high rejection with high-pressure resistance in the large seawater desalination market.

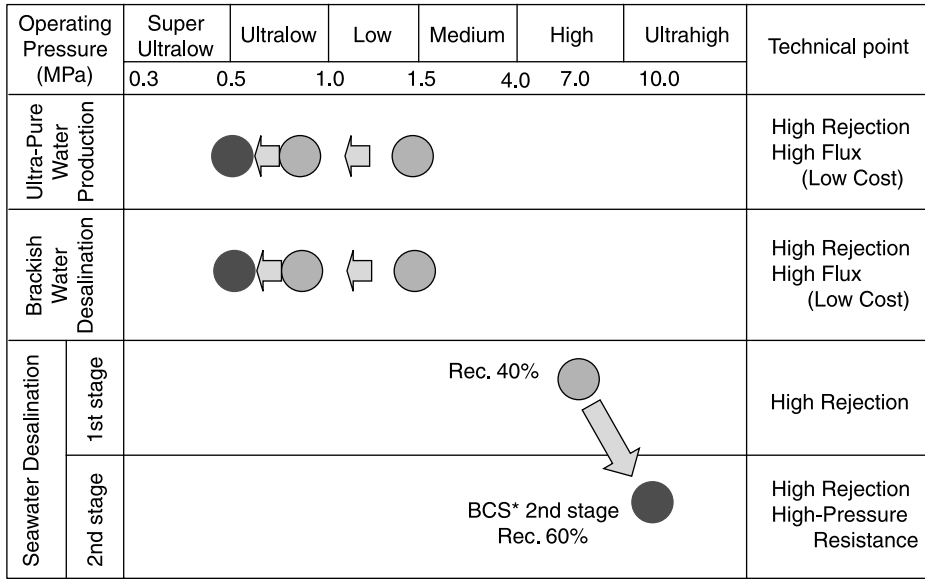

*Brine Conversion System

Figure 1.3 Technology trends in RO membrane.

1.4.1 Progress of Low-Pressure Membrane Performance in Brackish Water Desalination

Figure 1.4 shows the progress of low-pressure membrane performance trends in RO membrane on brackish water desalination from the 1970s to the 1990s, including industrial water treatment such as ultrapure water production. In the 1970s much effort was devoted to

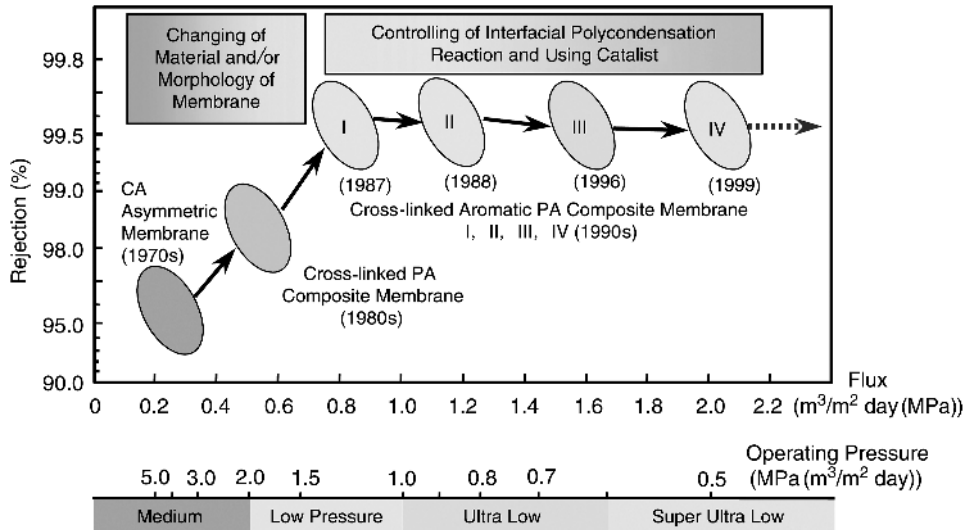

Figure 1.4 Performance trends in RO membrane for brackish water desalination.

TABLE 1.3 Typical Performance of Toray's Brackish Water RO Elements

Type of Membrane	Low Pressure		Ultralow Pressure	Super-ultralow Pressure
	I	II	III	IV
Name of membrane element (in market: year)	SU-720 (1987)	SU-720L (1988)	SUL-G20 (1996)	SUL-H20 (1999)
Performance				
Salt rejection (%)	99.4	99.0	99.4	99.4
Water permeability (m ³ /day)	26.0	22.0	26.0	26.0
Test condition				
Operating pressure (MPa)	1.5	1.0	0.75	0.5
Temperature (°C)	25	25	25	25
Feed concentration (mg/L)	1500	1500	1500	1500
Brine flow rate (L/min)	80	80	80	80

developing high-performance membrane materials and improving the membrane performance. As a result performance was improved with a new developed material of cross-linked aromatic polyamide and by developing membrane morphology and fabrication technology. The cross-linked fully aromatic polyamide composite membrane developed in 1987 has four or five times larger water flux and five times higher product water quality than those of the CA membrane (Kurihara et al., 1987). Since 1987, membrane performance has been drastically developed. On the basis of the development of cross-linked fully aromatic polyamide composite membranes, RO membrane performance of brackish water desalination has improved very rapidly. Typical performances of the RO elements for brackish water desalination are shown in Table 1.3. The ultralow-pressure membrane, which can be used at ultralow pressures such as 0.75 MPa, has been developed, which saves on the operating cost (Ikeda et al., 1996). And now the super-ultralow-pressure membrane elements, which can be used at super-ultralow-pressure, such as 0.5–0.3 MPa, have been developed (Fusaoka, 1999). This membrane has three times the water permeability than the ordinary low-pressure RO membrane. This membrane can operate with one-third the pressure of a low-pressure membrane.

1.4.2 Progress of RO Membranes for Seawater Desalination

The progress of RO membranes for seawater desalination is shown in Figure 1.5 (Kurihara et al., 1994a). It is very important to increase the water recovery ratio on seawater desalination systems to achieve further cost reduction. Most seawater RO desalination systems in use today are confined to approximately 40% conversion of the feed water (salt concentration 3.5%), since most of commercially available RO membrane do not allow for high-pressure operation of more than around 7.0 MPa.

Recent progress on high-pressure–high-rejection spiral wound (SW) RO elements, combined with proven and innovative energy recovery and pumping devices, has opened new possibilities to reduce investment and operating cost. The progress of RO seawater desalination from a point of view of water recovery is shown in Table 1.4 (Moch, 2000).

Toray has developed a new low-cost seawater desalination system called the Brine Conversion Two-Stage (BCS) system, as shown in Figure 1.6, which provides 60%

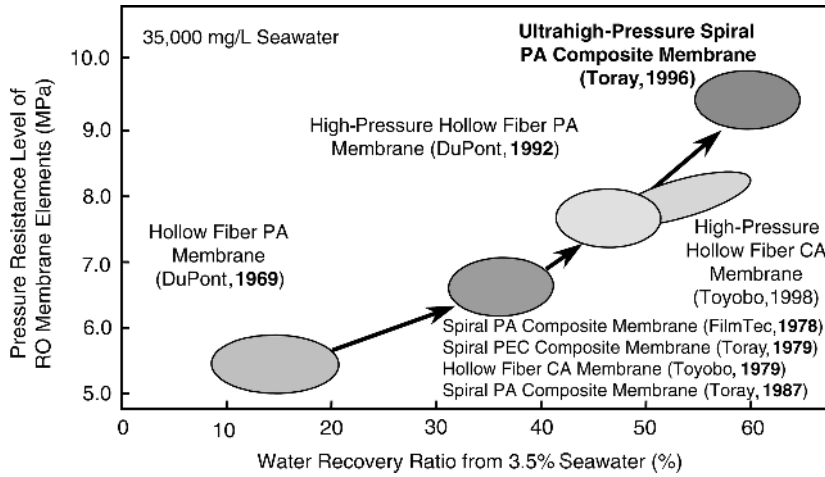

Figure 1.5 Performance trends in RO membranes for seawater desalination.

water recovery of freshwater (Yamamura et al., 1996). Ohya et al. (1996) and Nakao (1996) also suggest that higher recovery of RO seawater desalination by the BCS system is most effective in saving energy yet keeping a low operating cost.

As for achieving the 60% RO seawater desalination system, it is absolutely necessary to make the RO membrane element, which can be operated under very severe operating conditions, with high pressure and high feed water concentration such as 9.0 MPa and 5.8%. Toray has developed a high-performance membrane (BCM element) that can be operated at high pressure and high concentration conditions, as shown in Table 1.5.

1.4.3 High Boron Rejection SWRO Membrane

The removal of boron is a significant problem in SWRO desalination processes (Fukunaga et al., 1997). Boron exists as boric acid in the natural water, and boric acid mainly shows the

TABLE 1.4 Typical Performance of Toray’s Seawater RO Membranes

	Ultrahigh Pressure Seawater RO Membrane SU-820BCM	Seawater RO Membrane SU-820
Membrane material	Cross-linked fully aromatic polyamide	
Membrane morphology	Composite membrane	
Membrane substrate	Flat unweaved fabric	Unweaved fabric or taffeta
Feed water spacer	Special spacer	Normal spacer
Permeate spacer	Ultrahigh-pressure resistant	High-pressure resistant
Performance		
Rejection (%)	99.70	99.75
Water permeability (m ³ /day)	16.0	16.0
Test condition		
Feed concentration (mg/L)	58,000	35,000
Operating pressure (MPa)	9.0	5.5
Max. pressure (MPa)	10.0	7.0

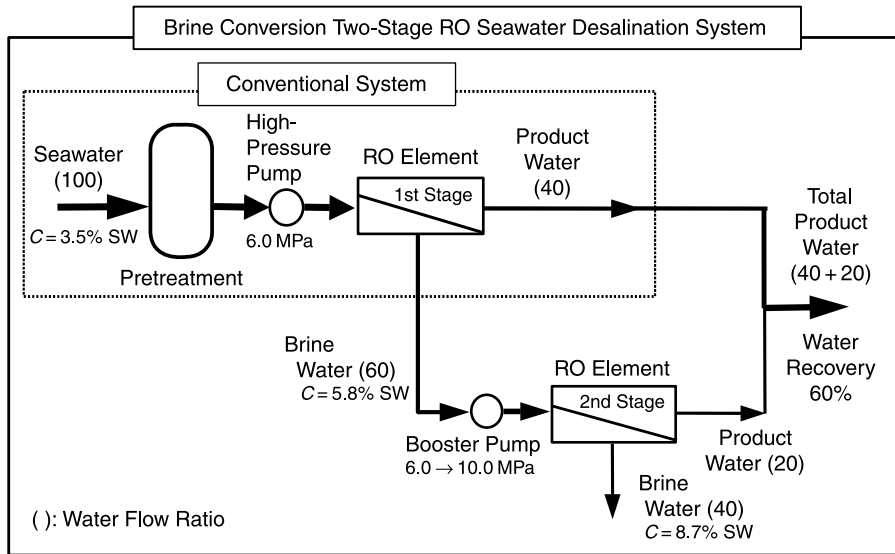

Toray's Patent: Japanese Patent Application No. 94-245184(1994), Application No. 96-108048(1996) priority. Granted: US, CA, RC(1998), AU(1998); Pending - JP, EP, KR, CH

Figure 1.6 Typical flow diagram of BCS system.

male reproductive tract when administered orally to laboratory animals. The World Health Organization (WHO) proposes that boron concentration in drinking water be below 0.5 mg/L as a provisional guideline value (WHO, 2004). However, especially in SWRO desalination fields, this is not an easy goal to meet because boron concentration in seawater is comparatively high. Although conventional SWRO membrane elements have shown a little more than 90% of boron rejection, it is still inadequate. It is difficult for RO membranes to remove boric acid in water for the following reasons: First, the molecular size of boric acid is so small that it is difficult to remove by size exclusion. Second, since boric acid has a pK_a of 9.14–9.25, it is not ionized in natural seawater with a pH of 7.0–8.0 and dissociates at pH 9 or more (Rodriguez et al., 2001). The boron rejection by the electric repulsive force between boric acid and the membrane cannot be expected in a neutral condition. Therefore, some posttreatment processes are necessary to meet the WHO proposal.

The conventional SWRO membrane element TM820, which is typical with Toray, has exhibited 91–93% boron rejection, which was the highest level achieved by commercialized SWRO membrane elements (Toray, 2004; Redondo et al., 2003; Hiro and Hirose, 2000). This membrane element series has been installed in a large number of SWRO

TABLE 1.5 Progress in RO Seawater Desalination Plant

	Unit	1980s	1990s	2000s
Recovery	%	25	40–50	55–65
Operating pressure	MPa (psig)	6.9 (1000)	8.25 (1200)	9.7 (1400)
Product water TDS	mg/L	500	300	<200
Plant energy consumption	kWh/m ³ (kWh/kgal)	12 (45)	5.5 (21)	4.6 (17.4)

Source: Moch (2000).

TABLE 1.6 SWRO Products Lineup Released from Toray^a

Type of Membrane	Standard Use	High Permeability	High Pressure	Ultrahigh Pressure
Name of membrane element	TM820-370	TM820L-370	TM820H-370	SU820BCM
Salt rejection, %	99.75	99.70	99.75	99.83
Product flow rate, m ³ /day (gpd)	23 (6000)	34 (9000)	21 (5600)	23 (6000)
Boron rejection, %	91–93	88–90	91–93	91–93
Membrane area, m ² (ft ²)	34 (370)	34 (370)	34 (370)	29 (320)
Max. operating pressure, MPa (psi)	6.9 (1000)	6.9 (1000)	8.3 (1200)	10.0 (1450)

^aTesting conditions were: applied pressure, 800 psi (5.52MPa) for others; recovery ratio, 8%; feed solution: 32,000ppm, NaCl with 5.0mg/L boron for others; pH = 8; temperature, 25°C.

plants. And Toray has commercialized many types of SWRO membrane elements, which are for different pressure ranges due to total dissolved solids (TDS) concentration and temperature of the seawater, as shown in Table 1.6. However, the highest boron rejection in those membrane elements is 91–93%, which is the same as TM820. This means that the improvement of boron rejection by membrane material had been sluggish for a while. Meanwhile, the new membrane element TM820A was developed based on the following two concepts: (1) reduction of affinity with boric acid by control of hydrophobic property and functional groups may reject boric acid selectively, and (2) molecular structure design was considered as blocking the boric-acid-permeable large pore (Taniguchi et al., 2004). TM820A exhibited 94–96% boron rejection with high TDS rejection and high water productivity. The specification and typical performance of TM820A is shown in Table 1.7.

Seen from various viewpoints, a single SWRO system is the most ideal. Therefore, to evaluate the performance of TM820A, the amount of boron that TM820A could remove by a single-stage operation was estimated. Table 1.8 shows the permeate boron concentration that corresponds to the boron rejection performance used by membrane elements when each region of seawater is treated by a single-stage SWRO operation considering the aging factor. According to Table 1.8, TM820A meets the Japanese guidelines of below 1 mg/L of boron concentration by a single-stage operation. But in severe conditions, for the WHO guideline grade and the Middle East seawater treatment, certain posttreatment processes are still needed. If 97% of boron rejection performance is gained, the WHO grade will be enabled until the Southeast Asia seawater treatment. Furthermore, at 99% boron

TABLE 1.7 Specifications and Typical Performances of TM820A^a

Name of Membrane Element	TM820A-370
Salt rejection, %	99.80
Product flow rate, m ³ /day (gpd)	21 (5500)
Boron rejection, %	94–96
Membrane area, m ² (ft ²)	34 (370)

^aTesting conditions were: applied pressure, 800 psi (5.52MPa); recovery ratio, 8%; feed solution: 32,000ppm, NaCl with 5.0mg/L boron; pH = 8; temperature, 25°C.

TABLE 1.8 Permeate Boron Concentration by a Single-Stage SWRO Operation (Calculated)^a

Seawater (Temp., TDS conc., Boron conc.)	Permeate Boron Concentration (mg/L)			
	Boron Rejection Performance of Used Membrane Element			
	90%	95% (TM820A)	97%	99%
Japan (25°C, 3.5%, 5 mg/L)	1.5	0.9	0.4	0.2
Southeast Asia (32°C, 3.5%, 5 mg/L)	1.6	1.0	0.5	0.2
Middle East (38°C, 4.5%, 7 mg/L)	3.0	2.0	1.1	0.4

^aAssumed conditions: Plant: 7 elements/vessel, 14 l/mh; operation: 25°C, pH 8.0, 800 psi, 3.5 L/min, recovery ratio 40%, after 3 years. Japanese law grade: <1.0mg/L, WHO guideline grade: <0.5 mg/L.

rejection performance, the WHO guideline grade will be enabled even in the Middle East seawater treatment.

Recently, Toray has been investigating SWRO membranes that focus on the removal of boron by the improvement of membrane performance. The history and future prospects of the boron removal at Toray and other companies are shown in Figure 1.7. Until 2000, although the boron rejection was also improved as various membranes were developed in each company, it was 90% at best. In the next period, from 2000 to 2003, the membranes in which a little more than 90% of boron rejection was shown were released, and these serve as main items for each company now.

From 2003 to 2005, Toray developed and released TM820A, whose performance was appreciably improved, and offered the membrane that showed around 95% boron rejection prior to other companies. However, the supportive systems are still required to meet the WHO proposal even by using TM820A as above. Thus, the next target is 97 or 99% boron rejection performance of renovative membrane. The further development of a new

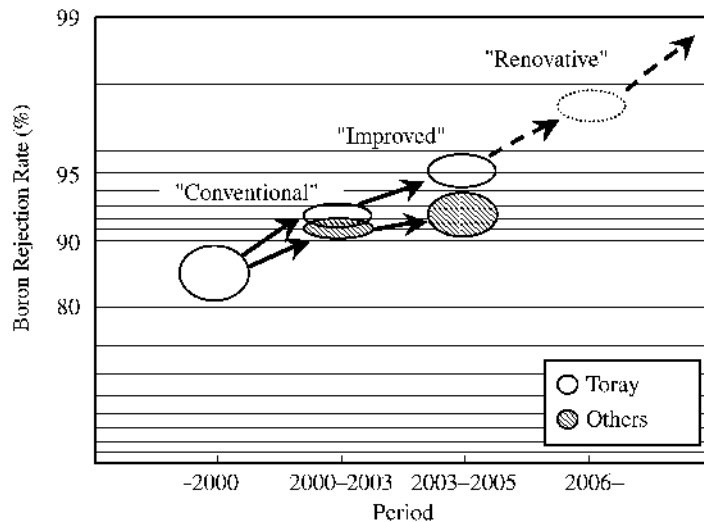

Figure 1.7 History and prospect of boron rejection performance of SWRO membrane element in Toray and comparable companies.

TABLE 1.9 Large Seawater Desalination Plants Utilizing RO Process (as of July, 2005)

No.	Country	Location	Capacity (m ³ /d)	In Operation (year)	Membrane Supplier
1	Israel	Ashkelon	272,520	2005	Dow
2	UAE	Taweelah	227,300	2006	Undecided
3	Algeria	Hamma	200,000	2006	Undecided
4	UAE	Fujairah	170,000	2003	Hydranautics
5	Trinidad & Tobago	Point Lisa	136,000	2002	Toray
5	Singapore	Tuas	136,000	2005	Toray
7	Saudi Arabia	Tanbu	128,000	1995	Toyobo
8	Spain	Carponeras	120,000	2001	Hydranautics
9	Israel	Palmachim	92,250	2006	Toray
10	Saudi Arabia	Al Jubail III	90,900	2000	DuPont/Toray

renovative membrane that can meet the WHO proposal for every seawater continues (Tomioka et al., 2005). Table 1.9 summarizes large seawater RO desalination plants around the world. TM820A is installed in a large seawater RO desalination plant in Singapore.

1.5 REVERSE OSMOSIS/BIOFOULING PROTECTION

Biofouling has been regarded as the most serious problem in the operation of SWRO plants. The usual method to prevent biofouling is continuous chlorine dosing to intake seawater with sodium bisulfate (SBS) dosing at the RO portion. However, membranes performance deterioration occurred by oxidation in case of both polyamide and cellulose acetate membranes, and biofouling has not been solved yet. Toray has developed a new method that is effective to prevent biofouling on SWRO membranes and verified its effectiveness at actual plants.

First of all, by measuring the viable counts of bacteria at a plant, in case of the continuous chlorine/SBS dosing method, it was found that a number of bacteria drastically increased immediately after SBS dosing, as shown in Figure 1.8, and most of these bacteria were quite different from those found in raw seawater. Currently, the addition of SBS to feed water at relatively high concentration has been used for sterilization of RO membranes. However, when SBS was added to seawater, the pH was just dropped to 6, and most of the bacteria harbored in water were still alive. This result indicates that the sterilization ability of SBS is due to lower pH, and oxygen consumption with SBS only plays a role to repress the cell growth. Finally, Toray has developed a new agent, MT-901, which is effective in preventing biofouling on RO membranes. Adding MT-901 to seawater instead of SBS effectively killed bacteria in a few samples of seawater within a short time.

Finally, the effect of this method was verified at an SWRO plant. In this plant, when feed water was chlorinated and dechlorinated with SBS continuously and RO membrane modules were treated with SBS intermittently, differentiation pressure of the module increased gradually. MT-901 was used for membrane module treatment in place of SBS and the differential pressure decreased within 10 days. Moreover, using an intermittent chlorination method was effective to maintain the initial differential pressure with less concentration of MT-901 (Kallenberg et al., 1999).

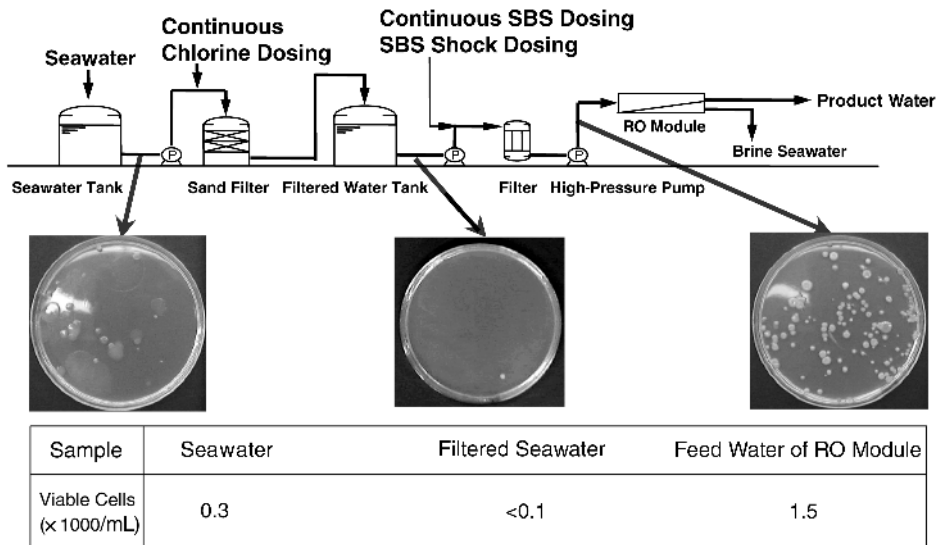

Figure 1.8 Viable cell count assessment in RO plant.

1.6 LOW-FOULING RO MEMBRANE FOR WASTEWATER RECLAMATION

Wastewater reclamation and reuse plants have been constructed and operated around the world. Table 1.10 shows large wastewater reuse plants. RO membrane is necessary for wastewater reclamation to make the water quality reusable. The largest RO plant is operated in Kuwait since 2005.

For RO membrane modules, stable operation is very important. Many organizations, universities, and companies have reported many kinds of operation troubles. Fouling, membrane deterioration, and hardware problems have mainly caused these troubles, and the major troubles, which occupy 80%, are fouling problems.

As described above, it is important to consider the (1) proper RO membrane elements with low-fouling property, (2) proper pretreatment technology before the RO membrane, and (3) suitable sterilization methods and cleaning technology (Kurihara et al., 2003).

TABLE 1.10 Large Wastewater Reuse Plants (as of July, 2005)

No.	Country	Location	Capacity (m ³ /d)	In Operation (year)	RO Supplier
1	Kuwait	Sulaibiya	310,000	2005	Toray
2	USA	Fountain Valley, CA	220,000	2007	Hydranautics
3	Singapore	Ulu Pandan	140,000	2006	Undecided
4	USA	West Basin, CA	75,000	1997–2001	Unidentified
5	Singapore	Kranji	40,000	2003	Hydranautics
6	Singapore	Bedok	32,000	2003	Hydranautics
7	Singapore	Seletar	24,000	2003	Toray
8	USA	Scottsdale, AZ	22,710	1998	Koch

The reasons for fouling of RO membrane are reported as consisting of chemical fouling, biological fouling, and scale precipitation.

It is estimated that chemical fouling is caused by the adsorption of organic materials such as humic substances and surfactants in the feed water or on the membrane surface. Humic substances have various chemical structures depending on the water origin, such as land water or seawater, and regions in the world. However, it has both hydrophobic groups of aromatic and linear structure and ionic groups of amino acid and carboxylic acid. The material of RO membrane is polyamide with hydrophobic and ionic properties. As mentioned above, chemical fouling depends on hydrophobic interaction and electrostatic interaction between organic materials in the feed water and membrane surface.

On the other hand, in case of biological fouling, the following estimations are reported: (1) microbe adsorption by hydrophobic or electrostatic interaction, (2) propagation of microbe with nutrition in the feed water, and (3) deposition of exhaust material of biological metabolism. Case 1 is a reversible phenomenon; however, cases 2 and 3 are irreversible phenomena, which are difficult to remove by simple chemical cleaning.

As a result of R&D activities, Toray has developed low-fouling RO membrane for wastewater reclamation. The low-fouling RO membrane has the same level of pure water permeability as conventional RO membranes, SU-700 and SUL-G, and also has low-fouling property with keeping water permeability against chemical and biological fouling during the operation (Yamamura et al., 2002).

The low-fouling property of membranes is evaluated with a nonionic surfactant aqueous solution. Test result shows that, in operation, low-fouling RO membrane has a relatively small permeability declaration ratio of 27%, compared with initial pure water permeability and shows stable operation. On the other hand, conventional fully aromatic polyamide membranes, SU-700 and SUL-G, show 36–47% declaration ratio, even if they show stable operation. And concerning the chemical cleaning properties, low-fouling RO membrane shows better recovery of permeability after chemical cleaning.

To evaluate the fouling property against microbes, adsorption property of a certain hydrophobic microbe and other hydrophilic microbes were measured. The hydrophobic microbe was severely adsorbed to conventional RO membranes and caused biological fouling of RO membranes. In case of low-fouling RO membranes, the adsorption property of the hydrophobic microbe is quite low, which is less than one-tenth of conventional RO membranes. Initial performance of low-fouling RO membrane element TML-20 is described in Table 1.11.

A test of wastewater reclamation using low-fouling RO membranes and conventional low-pressure RO membrane SUL-G10 has been carried out in a wastewater treatment facility in Japan, as shown in Figure 1.9. In this test, secondary effluent was directly filtered by ultrafiltration (UF) membrane and permeate was fed to both of the RO membranes. In case

TABLE 1.11 Initial Performance of Low-Fouling RO Membrane Element TML-20^a

Items	Performance Data		
Salt rejection (%)	99.5	99.5	99.5
Permeability (m ³ /day)	36.0	41.0	48.0

^aConditions: Pressure = 1.5 MPa, temperature = 25°C, feed water conc. = 1500 (NaCl mg/L), pH 6.5.

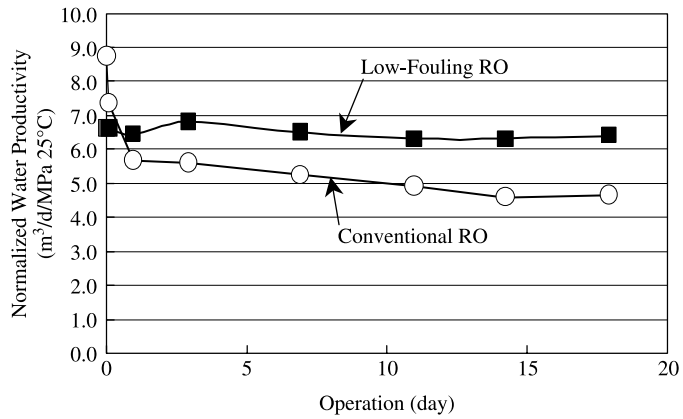

Figure 1.9 Water productivity of low-fouling RO compared with conventional RO.

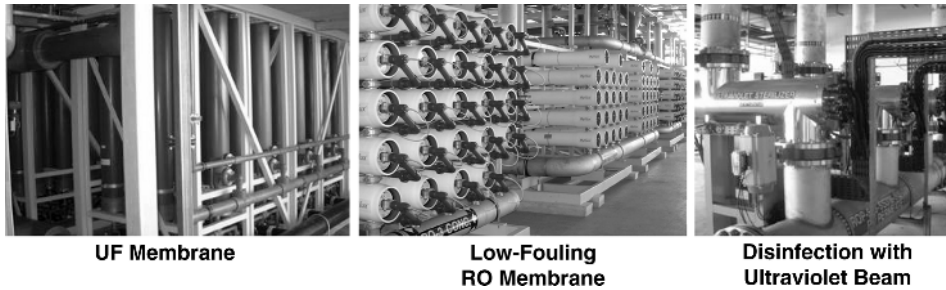

Figure 1.10 Wastewater reclamation and reuse plant in Singapore (24,000 m³/day).

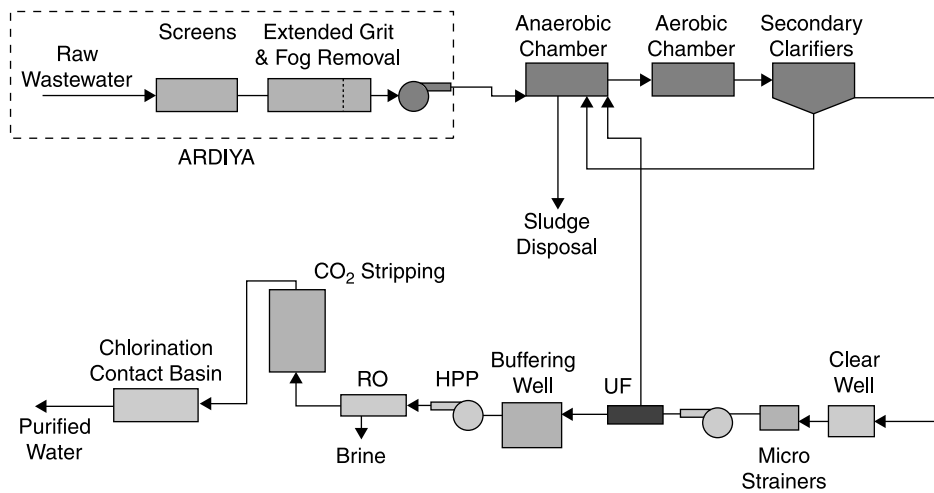

Figure 1.11 Process flow of wastewater reclamation and reuse plant in Kuwait (375,000 m³/day).



Figure 1.12 RO portion of wastewater reclamation and reuse plant in Kuwait.

of the SUL-G membrane, water permeability dropped to 60% of initial permeability in a day due to biological fouling; however, the permeability drop of low-fouling RO TML20 was smaller than that of SUL-G and the stable operation has been performed.

The low-fouling RO membrane is strongly required for the stable operation of the wastewater reclamation plant. Two large water reclamation and reuse plants have been operated in Singapore and Kuwait, as shown in Figures 1.10, 1.11, and 1.12.

1.7 CHLORINE TOLERANCE OF CROSS-LINKED AROMATIC POLYAMIDE MEMBRANE

Chlorine tolerance is a very important characteristic to design an RO membrane process because chlorine dosing to water process is commonly used as a disinfection for microorganisms. Many authors have studied chlorine tolerance of RO membranes as listed in Table 1.12.

In our literature, we studied three kinds of RO membranes: a cellulose acetate asymmetric membrane (SC-3000), a cross-linked N-substituted polyamide composite membrane

TABLE 1.12 Studies on Chlorine Tolerance of RO Membrane

Active Chlorine		Membrane Material		
HClO	ClO ⁻	Cellulose Acetate	Cross-linked N-substituted Polyamide	Cross-linked Aromatic Polyamide
—	yes	yes	—	—
yes	yes	yes	—	yes
yes	yes	—	yes	yes
yes	yes	—	yes	yes
yes	yes	—	yes	yes
yes	yes	yes	yes	yes

TABLE 1.13 Chlorine Degradation Rate Obtained from Each Membrane^a

Membrane	$(D_{AM}/k\delta)/(D_{AM}/k\delta)_0 =$	$A = A_0 +$
UTC-70	$\exp(1.6 \times 10^{-3} \times C^{0.5} \times t)$	$(7 \times 10^{-13}) \times C^{0.5} \times t$
UTC-60	$\exp(5 \times 10^{-6} \times C^{1.2} \times t)$	$(4 \times 10^{-15}) \times C^{1.2} \times t$
SC-3000	$\exp(5 \times 10^{-6} \times C^{1.5} \times t)$	$(9 \times 10^{-16}) \times C^{1.5} \times t$

^a C = chlorine conc. (ppm), t = chlorine exposure time (h).

(UTC-60), and a cross-linked aromatic polyamide composite membrane (UTC-70) using immersion and operating test conditions (Uemura and Kurihara, 2003). The degradation was observed as the increase in both solute and water permeation coefficients, which can be expressed as functions of a quantity of chlorine concentration to the X th power times the chlorine exposure time. It was found that the values of the X are in the range of 0.5–0.7 for cross-linked aromatic composite, 1.2 for cross-linked N-substituted composite, and 1.5 for cellulose acetate asymmetric. The value of X seems closely related to the degradation mechanism. In the case of rapid degradation, the degradation might be mainly caused by chlorination reaction, and the value of X should be close to 0.5. On the other hand, in the case of slow degradation, the degradation might be caused by oxidation reaction, and value of X should be close to 2. The morphological and structural changes due to the chlorination degradation were observed using electron microscopy and electron spectroscopy for chemical analysis (ESCA). It was clarified that, as the degradation reaction progresses, the membrane thickness is reduced and its looseness and fixed charge density are increased. The results are summarized in Table 1.13.

Using the equations in Table 1.13, the membrane performance of both solute permeation coefficient ($D_{AM}/k\delta$) and water permeate coefficient (A) after certain chlorine concentration (C) and exposure time (t) can be roughly predicted for each membrane. But some catalytic acceleration reactions, which may be caused by the iron ion and other heavy-metal ions in water, must be taken into account in actual cases.

REFERENCES

- Cadotte, J. E. (1985). Evolution of composite reverse osmosis membrane. In *Materials Science of Synthetic Membranes*. ACS Symposium Series 269. American Chemical Society, Washington, DC, p. 273.
- Fukunaga, K., Matsukata, M., Ueyama, K., and Kimura, S. (1997). Reduction of boron concentration in water produced by a reverse osmosis sea water desalination unit. *Membrane* 22(4), 211.
- Fusaoka, Y. (1999). Super ultra low pressure composite reverse osmosis membrane elements for brackish water desalination and ultrapure water production. *Membrane* 24(6), 319–323.
- Hiro, A., and Hirose, M. (2000). Development of the high boron removal reverse osmosis membrane element for seawater desalination. *Nitto Giho* 40, 36.
- Ikeda, T., Fusaoka, Y., Uemura, T., Tonouchi, T., and Fujino, H. (1996). Advanced ultra low pressure reverse osmosis membrane elements having a high water flux and a high solute rejection. In *Preprints of International Congress on Membranes and Membrane Processes*, Yokohama, Japan, Aug. 18–23, p. 182.
- Kallenberg, K., Jose, P. V., Yamamura, H., and Kurihara, M. (1999). Brine conversion (BCS) enhances SWRO desalination case histories, operating data, novel design features. In *Preprints of IDA World Congress*, San Diego, USA, Vol. II, Aug. 29–Sept. 3, pp. 101–107.

- Kurihara, M., Fusaoka, Y., Sasaki, T., Bairinji, R., and Uemura, T. (1994a). Development of cross-linked fully aromatic polyamide ultra-thin composite membranes for seawater desalination. *Desalination* 96, 133.
- Kurihara, M., Himeshima, Y., and Uemura, T. (1987). In *Preprints of ICOM*, p. 428.
- Kurihara, M., Matsuka, N., Fusaoka, Y., and Henmi, M. (2003). Newly developed wastewater treatment systems using separation membranes. In *Proceedings Water Reuse & Desalination Conference*, Suntec Singapore, Singapore, Feb. 25–27.
- Kurihara, M., Uemura, T., Himeshima, Y., Ueno, K., and Bairinji, Y. (1994b). Development of crosslinked aromatic polyamide composite reverse osmosis membrane. *Nippon Kagaku Kaishi* 1994(2), 97–107.
- Moch, I. (2000). The case for and feasibility of very high recovery sea water reverse osmosis plants. In *Preprints of ADA Conference*, Lake Tahoe, USA.
- Morgan, P. W. (1965). Condensation polymers: By interfacial and solution methods. In *Polymer Reviews*, Vol. 10. Wiley, New York.
- Nakao, S. (1996). Sea water desalination process for high recovery of fresh water by reverse osmosis. *Bull. Soc. Sea Water Sci. Jpn.* 50(6), 406–412.
- Ohya, H., Suzuki, T., and Nakao, S. (1996). Proposal and technological breakthrough of an integrated system for the complete usage of sea water. *Bull. Soc. Sea Water Sci. Jpn.* 50(6), 389–395.
- Redondo, J., Busch, M., and Witte, J. D. (2003). Boron removal from seawater using FILMTEC™ high rejection SWRO membranes. *Desalination* 156, 229.
- Rodriguez, M., Ruiz, A. F., Chilon, M. F., and Rico, D. P. (2001). Influence of pH in the elimination of boron by means of reverse osmosis. *Desalination* 140, 145.
- Scala, R. C., Ciliberti, D. F., and Berg, D. (1973). Interface condensation desalination membrane. U.S. Patent 3,744,642.
- Taniguchi, M., Fusaoka, Y., Nishikawa, T., and Kurihara, M. (2004). Boron removal in RO seawater desalination. *Desalination* 167, 419.
- Tomioka, H., Taniguchi, M., Okazaki, M., Goto, S., Uemura, T., and Kurihara, M. (2005). Milestone of high boron rejection seawater RO membrane. In *Proceedings of IDA World Congress on Desalination and Water Reuse*, Singapore, Sept. 11–14.
- Toray (2004). Brochure of TM800. Tokyo, Japan.
- Uemura, T., and Kurihara, M. (2003). Chlorine resistance of reverse osmosis membranes and changes in membrane structure and performance caused by chlorination degradation. *Bull. Soc. Sea Water Sci. Jpn.* 57, 498.
- World Health Organization (WHO) (2004). *Guidelines for Drinking Water Quality*, 3rd ed. WHO, Geneva.
- Van Heuven, J. W. (1976). Dynamic membrane. U.S. Patent 3,996,318.
- Yamamura, H., Henmi, M., and Inoue, T. (2002). In Development innovative MF and RO membrane for wastewater treatment and reclamation. In *Proceedings of the 2nd International Conference on Application of Membrane Technology*, Beijing, China, Sept. 27–29.
- Yamamura, H., Kurihara, M., and Maeda, K. (1994, 1996). Japanese Patent Applications H06-245184 and H08-108048.

