

Available Energy Resources

1.1 CIVILIZATION AND THE SEARCH FOR SUSTAINABLE ENERGY

Many thousands of years ago, our ancestors knew how to produce fire and they used it for several different purposes, including warming themselves and preparing food. They discovered that energy could be liberated from burning wood. The energy-liberating material was defined as fuel, and this led to the recognition that wood is a fuel. Early civilizations depended on this fuel for a long time. To improve their living conditions, humans searched for new forms of sustainable energy. This exploration resulted in the invention of wind-driven wheels that could be used to pump water from wells. Before this discovery, water was pulled from wells by human energy. This led to a correlation that wind is a source of energy. The wheel was also found useful for transportation forming a part of a chariot that could be rotated when drawn by horses.

During the 18th century, the most commonly used forms of energy were derived from wood, water, horses, and mills. The composition and structure of these materials were mysteries, and more so how the energy was liberated from them. These mysteries led to detailed investigations into the structure of matter by numerous scientists, including Thompson, Dalton, Faraday, Madame Curie, Rutherford, Neils Bohr, Einstein and Gibbs. This search for understanding the composition and structure of matter result in astounding discoveries in science, including the discovery and understanding of molecules and atoms.

The energy liberates upon combustion and products produced as results of combustion were established during this period. During the 18th century, as mentioned in the beginning of the paragraph, it was demonstrated that alcohol could be produced by the destructive distillation of wood, and that alcohol could be used as a source of energy. A realization that wood could be replaced by alcohol and that it could do the job much more effectively resulted in the use of alcohol as a source of energy. Coal was used as a source of energy for running steam engines.

In the 19th century, organic chemists synthesized hydrocarbons and determined the energies available from them. The twentieth century led to the search for naturally available sources of hydrocarbons, and the discovery, that oil and natural gas contain them paved the way for their utilization as energy sources in transportation. The rapid utilization and resulting depletion of these naturally occurring sources by mankind is leading to the search for viable alternatives. In addition, hydrocarbon-based energy sources are responsible for pollution of the atmosphere. These energy sources release

Introduction to Hydrogen Technology

by Roman J. Press, K.S.V. Santhanam, Massoud J. Miri, Alla V. Bailey, and Gerald A. Takacs
Copyright © 2009 John Wiley & Sons, Inc.

carbon dioxide and carbon monoxide gases. Such gases are causing global warming (Section 1.3).

The 21st century is facing challenging problems, with faster depletion of fossil fuels and pollution arising from their use. Energy sources that are sustainable and producing negligible pollution are needed. In this context, hydrogen and fuel cells are being considered, but their exploration and use require policy decisions. The United States depends heavily on imported oils, and the infrastructure has been built on the imported oils and natural gases. In order to switch over to other fuels free from the restrictions discussed above, a smooth transitional infrastructure needs to evolve. It is unrealistic to think that an entirely new energy source will be discovered to satisfy our needs.

A symbol of early human ingenuity is the first step pyramid, built for King Zoser in 2750 B.C. in Saqqará/Egypt. Similarly, the “energy pyramid” represents another advancement in human ingenuity. As the “food pyramid” represents a balanced approach to a healthy lifestyle, the energy pyramid (Figure 1.1) represents a balanced approach to consuming renewable and nonrenewable energy sources. With the gradual depletion of most nonrenewable sources of hydrocarbon-based fuels, the energy pyramid contains a diverse proportion of renewable fuels—hydro, solar, and wind power, along with various biomass-produced fuels.

During the 19th century, hydrogen was experimented with as an energy source, and Sir William Grove demonstrated in 1839 that hydrogen and oxygen would combine to produce electricity. The product of the reaction was water. He called the device a fuel cell. In this method of producing electricity, there is no pollution generated and it is environmentally friendly for transportation. These two factors are very important in the 21st century. President George Bush, spoke of the potential of hydrogen as a future energy source in his address to the National Building Museum on February 6, 2003. He stated that, “Hydrogen fuel cells represent one of the most encouraging, innovative technologies of our era,” and predicted that any obstacles in building hydrogen-based technology could be overcome by thoughtful research by scientists and engineers.

The United States is in a unique situation in its energy consumption. Growth was exponential in the second half of the 20th century. In the 21st century, the United States

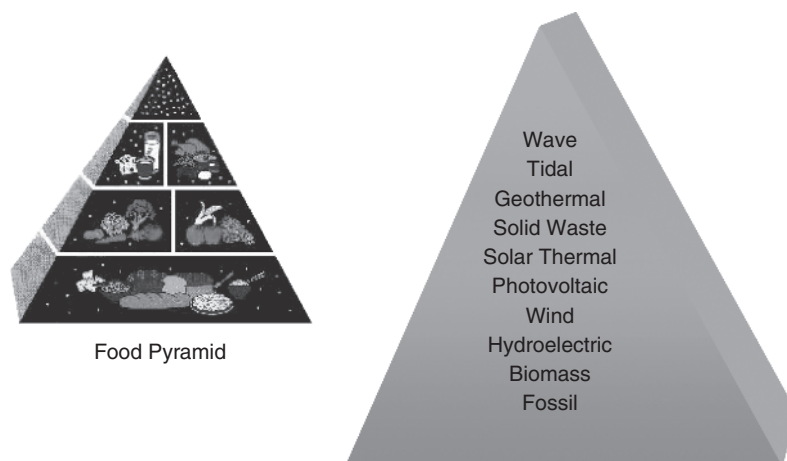

Figure 1.1 Energy pyramid.

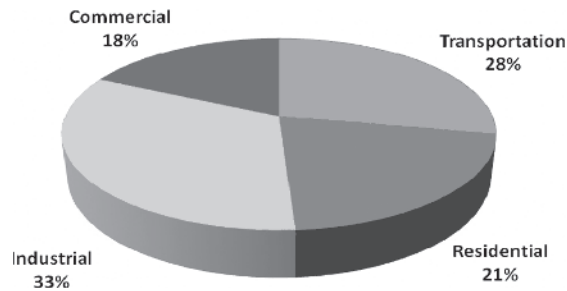

Figure 1.2 U.S. energy use by sector.

consumes 25% of the world's energy supplies which are distributed over the following four sectors: industrial use commercial use, transportation, and d) residential use (Figure 1.2). A deeper analysis shows that these four sectors showed a 300% increase in the annual usage since 1950. This trend has resulted in faster depletion of fossil fuels and greater environmental effects. Petroleum and gas reserves (fuels) are being rapidly depleted at a rate of a thousand times faster than the fuels are formed and stored. With the economic viability of the United States closely linked to fuel supplies from unstable regions around the globe, additional problems are likely to arise in future. If domestic supplies of fuels decline, the need for importing fuels will increase. With current evidence for the imported fuel prices increasing year by year, the fuel need and cost are likely to severely escalate in the near future.

Increased use of fossil fuels has had negative environmental effects: oil spills endanger aquatic and plant life, contaminate beaches and soil, and cause erosion of large masses of land. It also results in global warming effects. If we wish to solve all these problems, then we have to find alternative sources of energy. Hydrogen is one of the alternative energy sources that the world could rely safely.

Industrialized society is built on the existing infrastructure and is primarily fueled by petroleum. If fuel prices are stable, then the infrastructure requires very little change and the status quo can be maintained. Unfortunately, the status quo does not address the problems of the future. Future needs can be met only by recognizing the problems generated by petroleum-based technology and making efforts to find energy sources free from these problems. Hydrogen-based technology appears to be an ideal solution in this context.

Hydrogen-based technology offers attractive options for use in an economically and socially viable world with negligible environmental effects. Hydrogen is everywhere on earth in the form of water and hydrocarbons. In other words, hydrogen as fuel produces water as the by-product, and water is the source for hydrogen. It is an ideal energy carrier and hence could play a major role in a new decentralized infrastructure that would provide power to vehicles, homes, and industries. Hydrogen is nontoxic, renewable, clean, and provides more energy per dollar. Hydrogen is also the fuel for energy-efficient fuel cells.

Fossil fuels such as oil and gas are being currently used to harvest hydrogen. This is not ideal, as it does not solve environmental issues that arise with the usage of fossil fuels. In the future, it will be necessary to use renewable energy sources such as wind, hydro, solar, biomass, and geothermal instead.

The stationary power generation based on fuel cell technology is a viable energy source and has been implemented in several places in the world. This technology provides a drastic reduction in carbon dioxide output in comparison to the existing technology.

Leading automotive companies such as GM, Ford, Daimler-Chrysler, and Toyota have even made significant progress in developing advanced fuel cell propulsion systems using hydrogen. Hydrogen-powered fuel cells are approximately two times more efficient than gasoline engines. With 650 million vehicles worldwide fueled by gasoline, the market potential is immense. Fuel cell power modules, using either proton exchange membranes or solid oxide, which potentially can be the source of distributed electric power generation for business and home use.

The purpose of this book is to introduce the reader to the fundamental, chemistry-based aspects of hydrogen technology. It also provides information on renewable energy, hydrogen production, and fuel cells. The latest developments and current research on alternative fuels are discussed. The core topics include acid-base chemistry, reaction topics, chemical equilibrium, thermodynamics, electrochemistry, organic polymers, photochemistry, and environmental chemistry. The topics covered in this text are highly relevant to current international and national concerns about overconsumption of our planet's natural resources and the political implications of the United States' dependence on foreign oil to meet the majority of its energy needs. There are many reasons to search for renewable sources of energy—including, but not limited to energy conservation, pollution avoidance, and prevention. Hydrogen, being one of the cleanest and most abundant alternative energies, will most likely play a critical role in a new energy infrastructure by providing a cleaner source of power to vehicles, homes, and industries.

The authors are members of the Rochester Institute of Technology Renewable Energy Enterprise (RITree). They sincerely hope that this book will give a very good background on chemical aspects of hydrogen technology, including its potential in fuel cells and impact on environment. It is also the hope of the authors that this publication will contribute to the preparation of a workforce ready for future challenges in the areas of energy consumption, generation, and the rapid commercialization of both hydrogen-powered transportation and nonautomotive applications.

1.2 THE PLANET'S ENERGY RESOURCES AND ENERGY CONSUMPTION

On this planet, sources of energy are fossil fuels, the sun, the wind, water, and the earth (the latter includes geothermal and nuclear energy). Fossil fuels—oil (also called petroleum), natural gas, coal, and nuclear energy (splitting of uranium 235)—are abundantly used at present. Since these energy sources are expected to be depleted within a couple of centuries, they have been called “nonrenewable” energy sources. Only about 20% of our energy needs come from renewable sources. Examples in this category are solar energy, wind energy, hydroenergy, biomass, geothermal energy, tidal energy, and *hydrogen*. These sources are not efficient and research needs to be done to improve their efficiencies.

1.2.1 Energy Consumption

The total world consumption of energy amounted to 400 Quad (= quadrillion) Btu in 2000. A human being consumes about 0.9 GJ per day of energy, equivalent to burning 32 kg of coal per day, or as average energy supply, 10.4 kW. Any human being needs as nutrition only 0.14 kW or about 1% of the energy consumed per capita. Essentially all human activities involve consumption of energy, for example, construction of buildings, production of consumer goods, medicine, food, packaging of products, transportation, heating and

cooling, administrative work (computers), and even activities in our leisure time. Between 1850 and 1970, the world population tripled with the result that energy consumption has increased by a factor of 12.

1.2.2 Regional Differences

Unfortunately, energy consumption is not evenly distributed over the countries of the world. The developed rich countries, e.g., the United States, Europe, and Japan, consume about 80% of the worldwide energy and represent 20% of the world's population. Consumer habits differ by region. In the United States, people drive larger, less-efficient automobiles and buy larger homes than in many other countries, such as China or India. Currently, an American on the average uses 10 times more energy than the average Chinese and 20 times more than the average Indian. However, energy consumption is rising fastest in the developing countries.

1.2.3 Distribution by Economic Sector

Transportation accounts for 30% of the world's energy consumption, mainly due to the use of passenger cars. There are more than 531 million cars used worldwide and about 25% of these are being driven in the United States. In Europe and Japan, more mass transportation is used, often encouraged by government policies such as high taxes for car registration and subsidies for mass transport. Since most automobiles run on petroleum-based gasoline, the higher use of mass transportation significantly reduces production of greenhouse gases and global warming (see Section 1.3) and causes less pollution. Approximately a third of the world's energy is used in residential and commercial buildings, for heating, cooling, cooking, and other appliances. Americans use about 2.4 times the energy of Europeans, due to larger homes and more appliances. The average size of the living space for a citizen in the United States is about 25 times that of a person on the African continent. Another third of the world's energy is used in industry for the production of various goods, such as consumer products, cars, buildings, food, etc.

1.2.4 Differentiation by Type of Energy Resource

Figure 1.3 shows the consumption by energy source for the last three decades along with projections up to 2020. In 2000, close to 150 Quad Btu of the energy we used was from petroleum, followed by another 70 Quad Btu from natural gas, about 70 Quad Btu from coal, and 15 Quad Btu nuclear fuel. The remainder was from renewable energy resources (4.5).

1.2.5 Meeting the Energy Demands of the Future

Improved technology has helped to increase energy efficiency, particularly of the renewable energy resources. However, since the world's economy is also steadily increasing, the consumption of energy grows by about 2% every year, and the demand for energy will only increase.

1 Quad = 1.055×10^{18} Joules

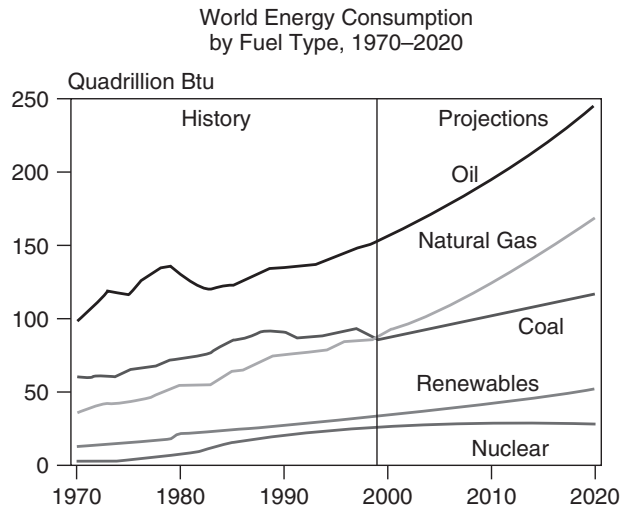

Figure 1.3 Consumption by type of energy source. [Source: EIA (Energy Information Administration), International Energy Outlook 2000, PPT by J. E. Hakes; available at <http://tonto.eia.doe.gov/FTP/ROOT/presentations/ieo2000/sld002.htm>.]

1.3 THE GREENHOUSE EFFECT AND ITS INFLUENCE ON QUALITY OF LIFE AND THE ECOSPHERE

We live on a planet that derives energy for all our activities from the sun. We wash our clothes in water and dry them in the sun. We get hydroelectric power from the evaporation of water by the heat of the sun. The green plants (trees, algae, etc.) on our planet perform photosynthesis using solar energy. There are many other applications of solar energy, such as in solar heaters, photovoltaic cells producing electricity, photo galvanic and photo biological processes.

The sun produces solar radiation by a nuclear process and the solar spectrum spans a wavelength of about 0.03 nm to 14,000 nm. Of these different wavelengths of radiation emitted by the sun, the highly energetic ones (gamma rays, X-rays, and ultraviolet rays) spanning a wavelength region of 0.03–300 nm, are filtered by the atmosphere above our planet. The other wavelengths enter our atmosphere. The radiation that reaches the earth's surface is now subjected to reflection by the atmosphere, the clouds, and the earth's surface. The total solar radiation that is reflected amounts to about 30 %. The balance of 70 % of incoming solar radiation is absorbed by the atmosphere, clouds, land, and oceans. Table 1.1 gives the estimated contributions by the different entities toward reflection and absorption. However, solar energy powers the life on the earth solely by absorption. Almost all of the short wavelength radiation coming from the sun (ultraviolet light) is absorbed by the ozone layer in the stratosphere. This absorption is very important as it protects life on the earth.

Figure 1.4 shows the path for the greenhouse effect and the solar radiation that is emitted and the radiation reaching the earth. Note that only part of the solar radiation reaches the earth.

TABLE 1.1 Pathways for the dissipation of solar radiation

Reflection		
Atmosphere		6%
Clouds		20%
Surface		4%
Absorption		
Atmosphere		16%
Clouds		3%
Land and oceans		51%

Source: http://en.wikipedia.org/wiki/Greenhouse_effect.

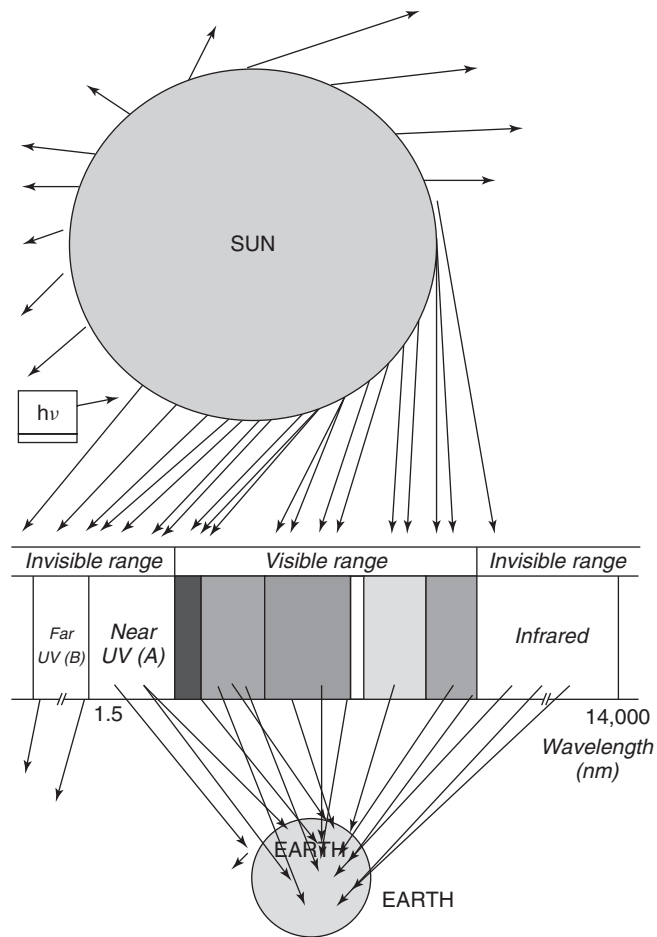

Figure 1.4 Solar radiation.

1.3.1 What Is the Effect of Solar Radiation Reaching the Earth?

The solar radiation reaching the earth heats the surface. This heating effect can be calculated from the radius of the earth (R) [0.635×10^7 m], solar constant (S) that describes the average amount of radiation that earth receives from the sun [1.37 kW/m^2], and Albedo (A) [the fraction of the radiation reflected by the planet] of the earth as given by equation (1.1).

$$\text{Amount of solar radiation reaching the earth's surface} = \pi R^2 S (1 - A) \quad (1.1)$$

This radiation heats up the earth to an effective temperature, T_e . The photons of the wavelengths shown by arrows pointing to earth in Figure 1.4 reach the entire surface and are not localized. If the earth emits radiation as a black body, the infrared radiation emitted will follow Stefan-Boltzmann law, according to which

$$\text{Amount of radiation reemitted by earth} = 4\pi R^2 k T_e^4 \quad (1.2)$$

where k = Stefan-Boltzmann constant.

Equating (1.1) with (1.2)

$$T_e = [S(1 - A)/4k]^{1/4} \quad (1.3)$$

By substituting the constants in equation (1.3) it is possible to estimate the effective temperature T_e . The earth's temperature based on this equilibrium model would be about $T_e = 253 \text{ K} (-20^\circ\text{C})$. This is not a suitable condition for life, as it would be a frozen world. However, this situation does not exist because of the greenhouse effect and we have an average temperature on the earth of about $288 \text{ K} (15^\circ\text{C})$.

1.3.2 How the Temperature Is Kept Higher than the Equilibrium Model

We have considered in the above discussions that the sun's radiation is a black body radiation that reaches the earth. The temperature of the sun is much higher than the earth (5880 K vs. 288 K) and also the earth's surface (earth diameter = 1.27×10^7 m and surface area $0.51 \times 10^{15} \text{ m}^2$) is much smaller than the sun (diameter = 1.39×10^9 m and surface area = $0.609 \times 10^{19} \text{ m}^2$). Due to these factors, Wein's displacement law proposes that the wavelength of radiation emitted by the earth should be longer than the one coming from the sun. It is typically in the infrared region of 1000 nm . The sun's radiation that reaches the earth is a visible wavelength of about 500 nm . As the earth radiates infrared radiation, it is absorbed by molecules in the atmosphere, typically molecules like carbon dioxide, water vapor, nitrous oxide, ozone, and methane. These molecules have the capability to absorb the infrared radiation and reemit it to keep the earth's temperature higher than predicted by the equilibrium model. The molecules absorbing the earth's radiation are called greenhouse gases and the process is known as the greenhouse effect. In other words, the greenhouse effect is a process of absorption of infrared radiation emitted from the earth by the greenhouse gases. Thus, most of the thermal radiation of the earth does not escape and is contained in the atmosphere. Only about 6 % of the total radiation from the earth escapes into space.

1.3.3 Quality of Life

The quality of our living depends on the environment we have around us. The effective temperature, T_e , is one of the deciding factors. If the atmosphere around us has a higher carbon dioxide level, then it will absorb more of the radiation emitted by the earth and reradiate it to the earth. This results in higher T_e on the earth and consequently in global warming. If global warming continues to take place, then a stage might be reached when our existence is threatened. Here we could compare the greenhouse effect of other planets. Venus is rich in carbon dioxide and hence it causes the greenhouse effect on its surface, where the temperature is such that a metal like lead can melt. On the other hand, Mars has very small amounts of greenhouse gases and hence produces a minimum greenhouse effect.

The carbon dioxide level in the earth's atmosphere has increased due to heavy industrialization from the original value of 313 ppm in 1960 and presently has reach a value of 375 ppm. The average temperature of the earth has increased by 0.5°C . This has been discussed as global warming in several scientific meetings. If this trend were to continue, then after a very long time, the effective temperature may not be tolerable for our living. At this stage, increased water evaporation will take place that will affect the quality and quantity of drinking water. It may cause higher rainfalls that may result in flooding. Another possible concern is in a rising sea level that can cause also flooding of the land. Increased temperature may cause spread of infectious diseases, forest fires, and demand for more air conditioning for our living.

1.3.4 The Ecosphere

Based on our current understanding of the greenhouse effect, it is desirable to examine the ecosphere, which is not only made up of the environment but also includes all the living things. It extends from the stratosphere to the deep abyss of ocean, with several interacting entities. We may divide the ecosphere into local ecosystems. Among these ecosystems within ecosystems, there may be interactions that will affect the atmosphere. With increasing industrialization (producing more carbon dioxide that is let into the atmosphere) and deforestation (absence of photosynthesis resulting in more carbon dioxide in the atmosphere) in the ecosphere, more of the greenhouse gases will surround us that would result in increasing the temperature on the earth. Another problem that we face is the destruction of the ozone layer (this layer filters ultraviolet rays from reaching the earth) by the fluorocarbons that will allow shorter wavelength radiation from the sun to penetrate through the layer and will have significant interaction with our ecosystem. This may bring about destruction of plants, animals, and humans living on our planet. Although the physical and chemical processes involved in greenhouse effect suggests caution in our industrialization and deforestation, it may be several millions of years before the effective temperature can reach the limit of destruction of life on our planet due to the above-mentioned causes.

The greenhouse effect has not been accepted by some scientists. The skeptics consider it as a normal and natural process on the planet that will not affect our living. However, those who accept the greenhouse effect tend to think that it can be reduced by controlling industrial and automobile exhausts. This step would reduce the carbon dioxide level in the atmosphere. Several countries are enforcing the automobile emission controls to a very low level (0–2%). Reductions can also be achieved by use of fuels that do not produce greenhouse gases. In this context, hydrogen technology plays a role as it is used as a fuel

to power cars (as fuel cells) and in home heating. The “Kyoto Protocol” enforces that industrialized countries should bring down the emissions of greenhouse gases by 5 % by 2010 as compared to 1990.

1.4 NONRENEWABLE ENERGY RESOURCES

Energy sources are nonrenewable when they are depleted in a foreseeable time, typically within a couple of hundred years. Nonrenewable energy is abundantly used and makes up most of our energy resources. Among the nonrenewable sources, the most prevalent are fossil fuels, which formed more than 200 million years ago, either from plants, resulting in coal, or from microorganisms, leading to petroleum and gas. Another nonrenewable supply of energy is available nowadays as nuclear fuel, based on the fission of heavy nuclei such as uranium 235. Besides these conventional sources, there are also oil sand and natural gas hydrates, which, however, are not commercially used in a significant quantity yet because of their relatively expensive extraction and production costs. The origin, production, use, and specific problems for each nonrenewable energy source will be further discussed below.

1.4.1 Petroleum

Petroleum was formed from microorganisms that were covered by sand and silt below the earth’s surface. Under pressure and heat, the organic material initially formed waxy solids, so-called kerogen, a precursor to gaseous and liquid organic compounds. Crude oil, or simply oil, as petroleum is also called, is typically a yellow/black viscous liquid that contains gaseous, liquid, and solid hydrocarbons. We will use terms *oil* and *petroleum* interchangeably. In refineries the petroleum is separated into purer fractions by a distillation process. The details on the fractionation of oil are described in Chapter 2, section 2.6.3.1. Figure 1.5 and Table 1.2 show the regions and major countries and their oil reserves.

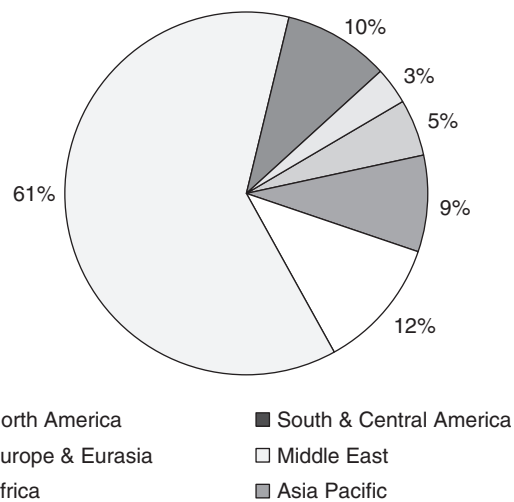

Figure 1.5 Oil reserves in the world in 2005. [Based on data from BP, available at <http://www.bp.com/productlanding..>]

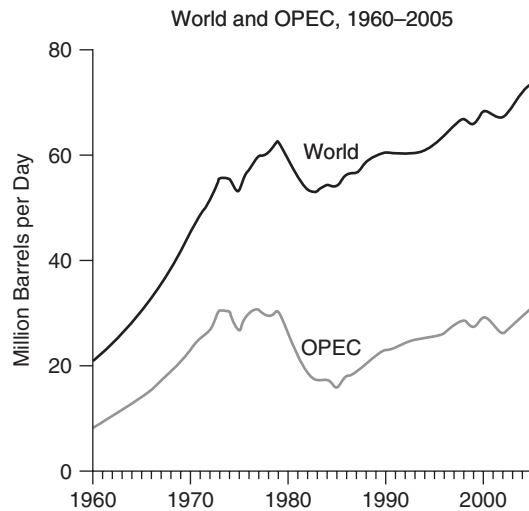

Figure 1.6 World petroleum production. [Source: Energy Information Administration/Annual Energy Review 2005 (http://www.eia.doe.gov/emeu/aer/pdf/pages/sec_10.pdf).]

Typically, oil is obtained by drilling into reservoirs beneath the earth's surface, including from platforms in the oceans. The oil reserves of the world amounted to 148 Gt in 2004. The area of the world in which the most oil is found is the Middle East, which has about 65% of the world reserves. Most of the world's oil is produced by the following countries: Saudi Arabia, Iran, Iraq, Kuwait, and the United Arab Emirates. These and other countries are members of the OPEC (Organization of Petroleum Exporting Countries). Other major oil-producing non-OPEC countries are Russia and Mexico. If nonconventional oil reserves are included, Canada would include significant reserves based on oil sand. Figure 1.6 indicates how oil production has increased within the last decades.

According to some estimates, world oil production has already peaked, however, the time of the peak varies by source. Several authors suggest that the peak will occur between 1980 and 2010. If we continue to consume petroleum at the current rate, we should run out of this fossil fuel in the next 40 to 50 years by most estimates. Over half the petroleum used by Americans comes from countries other than the U.S. Most of the oil is consumed for gasoline production, and more than half for fuels altogether, including diesel oil, heating oil, and airplane fuel. However, oil is also used to make more valuable products such as plastics, rubber, and medicines.

1.4.2 Natural Gas

Because natural gas is formed by similar anaerobic processes as oil, involving the decay of microorganisms several million years ago, most natural gas reservoirs are geographically close to oil reservoirs (conventional natural gas). Natural gas that occurs by itself in bedrock is distinguished as unconventional natural gas. A substantial amount of natural gas is methane (CH_4), with amounts ranging between 50 and 90%, with the remainder consisting of hydrocarbons with 2 to 4 carbons. Table 1.3 shows the countries' natural gas reserves. Natural gas is frequently transported through pipelines. Alternatively, it is liquefied at low temperatures (-160°C) and used as LNG (liquefied natural gas)

TABLE 1.3 World natural gas reserves: world proven natural gas reserves by country, 2005 and 2006

	2005	2006	% change 06/05
North America	7,420.0	7,590.0	2.3
Canada	1,633.0	1,665.0	2.0
United States	5,787.0	5,925.0	2.4
Latin America	7,312.0	7,716.0	5.5
Argentina	439.0	415.0	-5.5
Bolivia	740.0	740.0	0.0
Mexico	408.0	388.0	-4.9
Trinidad and Tobago	530.0	530.0	0.0
Venezuela	4,315.0	4,708.0	9.1
Latin America others	880.0	935.0	6.2
Eastern Europe	58,878.0	58,890.0	0.0
Romania	628.0	628.0	0.0
Former USSR	58,099.0	58,113.0	0.0
Eastern Europe others	151.0	149.0	-1.3
Western Europe	5,561.0	5,396.0	-3.0
Germany	257.0	255.0	-0.8
Netherlands	1,387.0	1,347.0	-2.9
Norway	3,007.0	2,892.0	-3.8
United Kingdom	481.0	481.0	0.0
Western Europe others	429.0	421.0	-1.9
Middle East	72,834.0	72,319.0	-0.7
Iran, I.R.	27,580.0	26,850.0	-2.6
Iraq	3,170.0	3,170.0	0.0
Kuwait	1,572.0	1,572.0	0.0
Oman	995.0	980.0	-1.5
Qatar	25,636.0	25,636.0	0.0
Saudi Arabia	6,900.0	7,154.0	3.7
UAE	6,060.0	6,040.0	-0.3
Middle East others	921.0	917.0	-0.4
Africa	14,132.0	14,165.0	0.2
Algeria	4,504.0	4,504.0	0.0
Angola	270.0	270.0	0.0
Egypt	1,895.0	1,940.0	2.4
Libya, S.P.A.J.	1,491.0	1,420.0	-4.8
Nigeria	5,152.0	5,210.0	1.1
Africa others	821.0	821.0	0.0

(continued overleaf)

TABLE 1.3 (Continued)

	2005	2006	% change 06/05
Asia and Pacific	14,928.0	14,824.0	-0.7
Australia	2,605.0	2,605.0	0.0
Bangladesh	436.0	435.0	-0.2
China	2,449.0	2,449.0	0.0
India	1,101.0	1,075.0	-2.4
Indonesia	2,769.0	2,659.0	-4.0
Malaysia	2,480.0	2,480.0	0.0
Myanmar	538.0	538.0	0.0
Pakistan	798.0	798.0	0.0
Papua New Guinea	428.0	435.0	1.6
Asia and Pacific others	1,324.0	1,350.0	2.0
Total World	181,065.0	180,899.0	-0.1
OPEC	89,419.0	89,193.0	-0.3
OPEC percentage	49.4	49.3	

Source: <http://www.opec.org/library/Annual%20Statistical%20Bulletin/interactive/FileZ/Main.htm> see then also :Oil and gas data, T34 World proven natural gas reserves by country, 1980–2006, last accessed: 6/1/2007.

and transported in containers. Due to its lower viscosity, LNG can be more easily transported and processed than oil. It is mostly used as fuel in industry and residential homes. Like oil it is also used effectively as precursor for the production of plastics and pharmaceuticals. Since natural gas is a purer mixture of hydrocarbons and contains less by-products than oil, it produces less environmentally problematic products when burned. For example, the level of nitrogen oxides or particulate matter is negligible. Another advantage of natural gas is that it is cheaper than oil. Natural gas itself does not have a characteristic smell. Like most volatile hydrocarbons, natural gas is highly flammable and therefore potentially hazardous. For detection in case of leakage, sulfur-containing compounds such as mercaptanes are added to it. These additives can be easily detected by their garlic-like smell and thus indicate whether the gas is present. The world's natural gas reserves are forecasted to last about 60 more years—slightly longer than our oil reserves.

1.4.3 Coal

Coal is the most abundant fossil fuel and is used to produce most (approximately 60%) of the world's electricity. It was formed about 300 million years (earlier than petroleum) ago from highly compressed residues of plants. Chemically, coal consists mainly of carbon, ash, which represents silicates and metals, and some sulfur. Some metals in coal are toxic, and sulfur is not desired, since it leads during combustion to sulfur oxides, which are hazardous in the environment. Coal appears in nature in different grades. At high pressure and low moisture anthracite is formed, which has, with 95%, the highest carbon content. Sub-bituminous coal has a lower carbon content of about 40%, however, its lowest sulfur content makes it useful. At lower pressure and higher moisture lignite is formed, which only contains 25% carbon. Coal was obtained traditionally by underground mining, but

TABLE 1.4 Proved recoverable coal reserves at end-2006 (million tonnes (teragrams))

Country	Bituminous & anthracite	SubBituminous & lignite	TOTAL	Share
United States of America	111,338	135,305	246,643	27.1
Russia	49,088	107,922	157,010	17.3
China	62,200	52,300	114,500	12.6
India	90,085	2,360	92,445	10.2
Australia	38,600	39,900	78,500	8.6
South Africa	48,750	0	48,750	5.4
Ukraine	16,274	17,879	34,153	3.8
Kazakhstan	28,151	3,128	31,279	3.4
Poland	14,000	0	14,000	1.5
Brazil	0	10,113	10,113	1.1
Germany	183	6,556	6,739	0.7
Colombia	6,230	381	6,611	0.7
Canada	3,471	3,107	6,578	0.7
Czech Republic	2,094	3,458	5,552	0.6
Indonesia	740	4,228	4,968	0.5
Turkey	278	3,908	4,186	0.5
Greece	0	3,900	3,900	0.4
Hungary	198	3,159	3,357	0.4
Pakistan	0	3,050	3,050	0.3
Bulgaria	4	2,183	2,187	0.2
Thailand	0	1,354	1,354	0.1
North Korea	300	300	600	0.1
New Zealand	33	538	571	0.1
Spain	200	330	530	0.1
Zimbabwe	502	0	502	0.1
Romania	22	472	494	0.1
Venezuela	479	0	479	0.1
TOTAL	478,771	430,293	909,064	100.0

Source: <http://www.wikipedia.com>. secondary source: http://www.eia.doe.gov/oiaf/aeo/supplement/pdf/suptab_114.pdf, last accessed: 4/1/2008.

more recently there is a trend to surface mining. The latter leads to less human casualties, however, causing more changes to the landscape an environment. Table 1.4 displays the world's reserves of coal.

Typically 80 to 90% of the coal is used in the country of origin, which is due to its relatively difficult transportation compared to oil and natural gas. Because of the environmentally hazardous gases formed during combustion, coal scrubbers or filters must be used before letting the gaseous product into the atmosphere. The expected time for the world's coal reserves to be depleted is within 200 years, by far the longest among the non-renewable fuels.

Besides electricity, coal can be converted to gases as "coal gas" for similar uses as natural gas. It can be also converted to syngas, a mixture of CO and H₂. As the price of oil and natural gas increases this option becomes more attractive. For the same reason, coal is liquefied (see, e.g., the Fischer-Tropsch process under Organic Chemistry, SectionII) to substitute for oil. As coke, coal is an important ingredient in the production of pig iron and steel. Fine carbon is used in plastics and rubber as a reinforcing agent.

1.4.4 Nuclear Energy

So far, the only form of nuclear energy that has been practically used is nuclear energy from the fission of heavy nuclei, such as uranium 235 or plutonium 239. Plutonium 239 is used mainly in breeder reactors, which have the advantage that they produce fissionable material. However, these types of reactors are politically unpopular because of their higher safety issues. In the past, France mainly built breeder reactors, whereas the United States or Germany did not.

Per kilogram of fuel, nuclear fission produces about 10,000 times the amount of energy as coal. However, nuclear reactors involve several disadvantages, which have made them less popular as an energy source. The major issue is that the fissionable isotopes are radioactive and would cause disease if they were to be exposed into the atmosphere, which would occur in the event of an accident. The worst accident so far happened in Chernobyl in the former Soviet Union in 1989, when the building holding the nuclear reactor exploded. Furthermore, even in the absence of an accident, the spent nuclear fuel rods still remain radioactive for several hundred thousand years. They must be carefully disposed. Currently, spent nuclear fuel rods are kept in containers below water pools. In the United States, they are to be eventually placed between aquifers under the Yucca Mountains, in Nevada. In addition, regular objects close to the nuclear core of the reactor such as instruments or clothes become radioactive and have to be treated with caution. The required safety and waste disposal measures make nuclear fuel less economical than simply based on its theoretical efficiency.

In research labs the fusion of hydrogen isotopes has been successful, but “cold fusion” at moderate temperatures remains a dream of scientists because it would be the most environmentally friendly source of energy, with resources that would last us more than 100 million years. Though attempted many times to date, fusion of nuclei at close to ambient temperatures could not be carried out successfully.

To obtain fissionable uranium 235 it has to be enriched from the more abundant uranium 238 as found in minerals, such as pitchblende. Table 1.5 shows the world’s uranium

TABLE 1.5 Known recoverable resources of uranium

	Tonnes U	Percentage of world
Australia	1,074,000	30%
Kazakhstan	622,000	17%
Canada	439,000	12%
South Africa	298,000	8%
Namibia	213,000	6%
Brazil	143,000	4%
Russian Fed.	158,000	4%
USA	102,000	3%
Uzbekistan	93,000	3%
World total	3,537,000	

Source: Reasonably Assured Resources plus Inferred Resources, to US\$ 80/kg U, 1/1/03, from OECD NEA & IAEA, Uranium 2003: Resources, Production and Demand, updated 2005. Available at <http://www.world-nuclear.org/info/inf75.htm>.

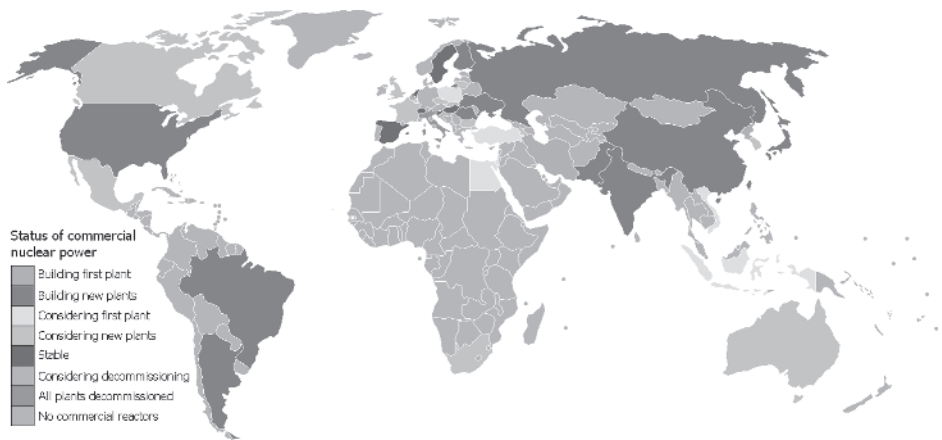

Figure 1.7 The world's nuclear power. [Source: Wikipedia, available at: http://en.wikipedia.org/wiki/Nuclear_power_by_country.]

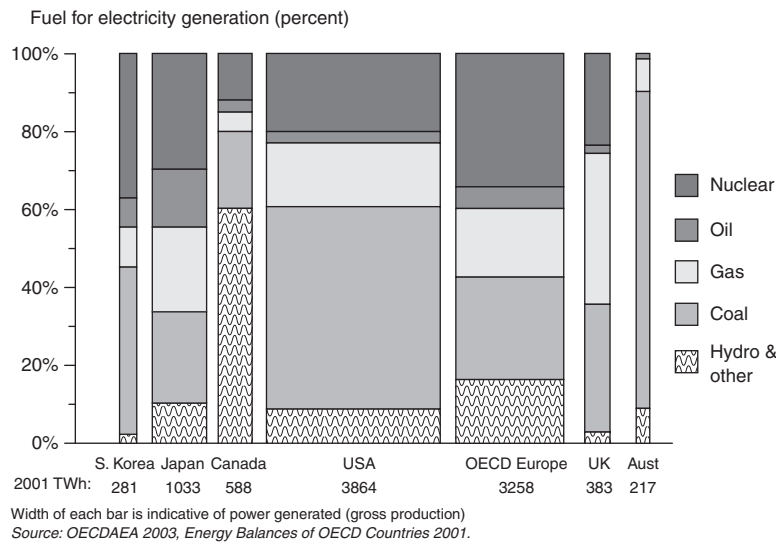

Figure 1.8 Electricity cost by different methods.

sources. About 16% of the world's electricity is obtained from nuclear power plants in about 30 countries. Figure 1.7 shows the status of commercial nuclear power plants of different countries. A comparison with other methods of electricity generation is illustrated in Figures 1.8 and 1.9. The world's reserves of uranium are expected to last about 50 years.

1.4.5 Outlook

Both oil and natural gas are used as precursors for hydrogen as fuel (see also section 2.6 in Chapter 2). Coal is currently the fastest growing energy source in the world. The major issue with all nonrenewable energy sources is that they create environmentally harmful and

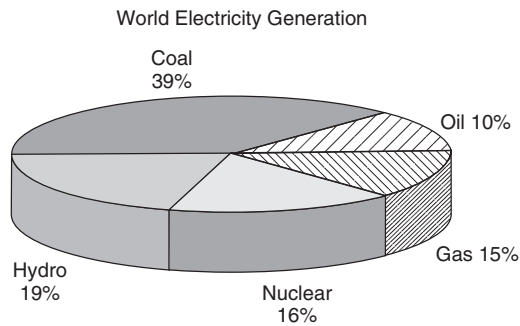

Figure 1.9 Different methods of generation of electricity (2003). [Source: OECD Factbook 2006-ISBN 92-64-03561-3-© OECD 2006.]

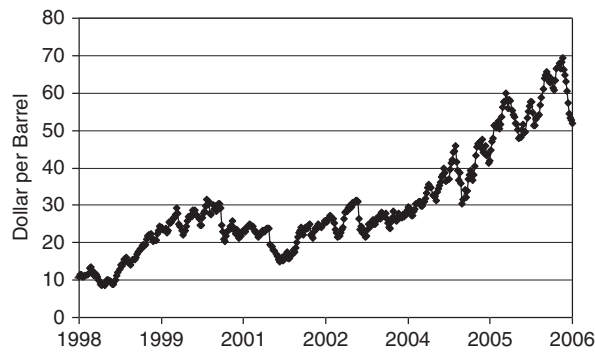

Figure 1.10 Change in oil price in the United States during 1998–2006. [Figure constructed from data from the EIA, available at http://tonto.eia.doe.gov/dnav/pet/pet_pri_wco_k_w.htm.]

dangerous products. Even when the toxic side products such as oxides of nitrogen or sulfur are removed, the fossil fuels are the major contributors to an increase in the emission of greenhouse gases, such as CO_2 and CH_4 , and thus global warming. One issue with hydrogen as a renewable energy source is that currently most sources of hydrogen production involve nonrenewable resources, for example, syn gas from coal or conversion of natural gas by so-called steam reforming: $\text{CH}_4 + \text{H}_2\text{O} \rightarrow \text{CO} + 3 \text{H}_2$. Figure 1.10 shows how rapidly the price of petroleum has been increasing in recent years. The current price in the middle of 2008 is \$145 per barrel.

1.5 RENEWABLE ENERGY SOURCES

The source for the renewable energies is the sun and is linked either directly or indirectly to the power of the earth's internal and external changes. The sun's heat and the earth's surface temperatures cause heating and cooling of air masses that become powerful winds. Those winds, along with heat from the sun and tidal forces, cause deep ocean currents and surface waves. The combined wind and the sun's heat cause the evaporation and precipitation that result in flowing rivers, lakes, and streams. The water and sunlight allow vegetation to grow as organic matter that can be transformed. Once captured, all of these energies can be converted for use as renewable sources of heat, electricity, and fuel.

1.5.1 Wind Energy

Wind is moving air that causes the uneven heating and cooling on the earth's surface due to the absorption of heat by the earth. In this process the land surfaces heat faster than water. The warmer air over land rises, resulting in the cooler air over the water moving out. This is a perennial process. A never-ending cycle of moving air causing atmospheric wind can be harnessed to produce large amounts of electricity. For achieving this, wind turbines are used. These turbines absorb the kinetic energy by turning aerodynamic blades. Typically, two or three blades are mounted on a shaft, forming a rotor. As wind flows over the blades, the low-pressure air is forced to lift and pull, turning the rotor. The rotor is connected to a drive shaft that spins a generator, which converts mechanical energy into electricity. One wind turbine can produce 1.5 to 4 million kilowatt hours (kWh) of electricity in a year (U.S. Department of Energy, 2005)

Upwind turbines have a wind vane that measures and communicates the direction of the wind to a yaw drive that reorients the rotor as the wind changes direction. The downwind turbines are reoriented by the wind and hence does not need a yaw drive. The rotor is computer-controlled in the start up at wind speeds of 8–16 miles per hour and shut down at wind speeds over 65 miles per hour. Some wind power systems combine with solar energy sources and hydrogen storage systems to store excess energy, with the added bonus of pure water as a by-product of its process.

Wind farms are clusters of turbines that produce electricity that is carried to a power grid for sale to utility companies. Wind power also provides *distributed energy*, which means it is on a small scale, close to the user and available immediately. In Europe, many individual homeowners share wind resources from small cooperative operations.

Offshore wind farms are clusters of turbines mounted on a floating platform, either close to shore or out in deeper water where they are less visible from shore. They have a 3 megawatt capacity. The electricity that is generated is transported via an undersea cable to an onshore power grid. By using this method, the public concern over the extensive use of land for turbine installation has been overcome.

Giant offshore turbine installations are increasing, particularly in Europe. Germany is developing a huge, 5 megawatt turbine that has 200 foot-long blades and stands 400 feet high. (National Geographic 2005). The government restrictions require that the turbines be installed at least 3 nautical miles from shore, which creates logistical problems and higher costs.

Wind power currently supplies less than 1% of the world's electricity and yet it is the fastest growing alternative energy source (National Geographic, 2005). However, due to unpredictable weather conditions the typical wind turbine efficiency of 20% of nominal power is estimated.

1.5.2 Solar Energy

Solar energy is the most effective and stable source of renewable energy on our planet. The radiation is emitted from the sun that is operating at a temperature of 6000 K; the wavelengths of radiation lie in the range of visible and near infrared. Using solar energy it has been shown that electricity, hot water, heating, and cooling for dwellings could be produced. Solar technologies that involve electricity have been designated as photovoltaic and ones using thermal energy have been called the thermal systems.

Photovoltaic (solar cell) systems convert sunlight directly into electricity. A solar cell is based on semiconductors that absorb the sunlight. The electrochemical processes in the photovoltaic systems will be described in more detail in Section 1.5.2.3.

The thermal system operates by absorbing the sun's radiation; it converts the stored heat into electricity for hot water preparation, building heating and cooling, and energy generation.

As shown in reference 7, the solar radiation budget is determined by the difference between the absorbed solar energy flux and the outgoing long wavelength radiation at the top of the atmosphere. These two components interact in a very complex way with most of the atmospheric processes tending to balance each other, thereby maintaining average constant climatic conditions. On a smaller temporal and spatial scale, this balance is disrupted, and the regional results of the radiation budget then contribute to atmospheric and oceanic circulations. In the context of climate perturbations, modifications in vegetation or in the formation of ice on the earth's surface can cause greenhouse gases such as carbon dioxide to increase. This will have adverse effects. As for interannual variations, the climatic anomalies such as the El Nino are likely to occur. This highlights the role of cloudiness in the radiation balance and explains why understanding of the interactions between clouds and radiation is a major goal of climate research (Figures 1.11 and 1.12). Accordingly (8), calculations at a conservative average of only 200 W/m^2 , the net yearly solar energy input to the planet corresponds to 2.22×10^{11} GW-year, equivalent to 7.577×10^{20} BTU, or, 757,700 quads, or, 1.29×10^{14} petroleum barrels/year: this amount is equivalent to 353,000 million barrels per day. The actual petroleum world consumption is around 70 million barrels per day. Therefore, the solar available energy power is 5,000 times the total energy power derived from actual world oil produced combustion (counted at 100% efficiency). Even at an energy transformation efficiency of only 10% and covering the energy collectors with only 1% of land surface, solar energy would provide about 6 times the actual oil used equivalent.

Solar energy is a sustainable, nonpolluting source of energy; however, implementation of current technology based on relatively lower efficiency of solar cells requires occupations of substantial earth area located in desert and sunny lands that are often very far from

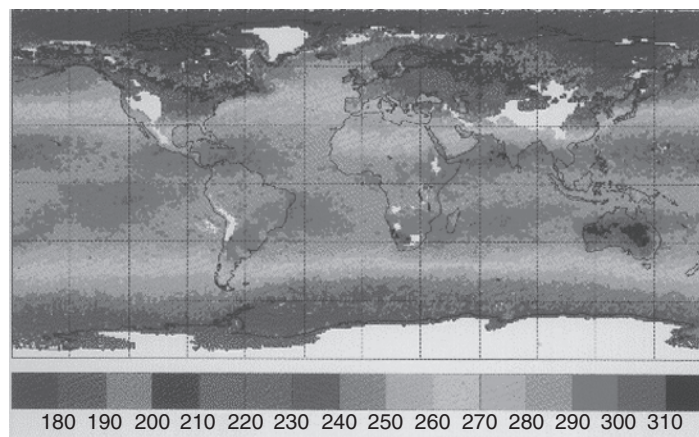

Figure 1.11 Thermal radiation contour. Outgoing thermal radiation (W/m^2) at the top of the atmosphere in January 1988 (7:30), calculated without clouds.

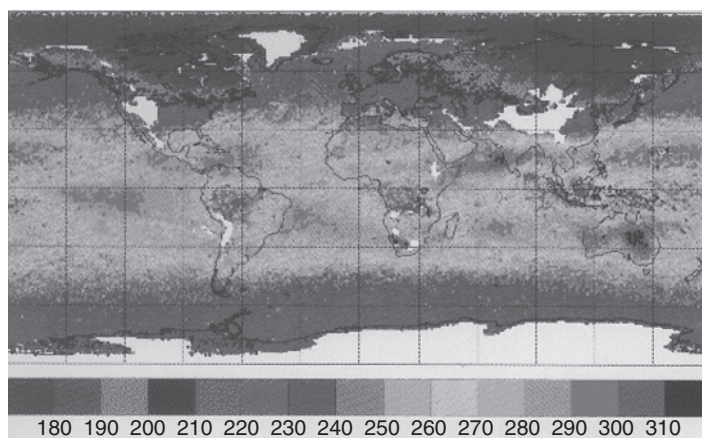

Figure 1.12 Thermal radiation contour. Outgoing thermal radiation (W/m^2) at the top of the atmosphere in January 1988 (7:30), with cloud cover. The cloud cover radically changes this zonal distribution by preventing a part of the thermal radiation, up to $60 \text{ W}/\text{m}^2$.

the main regions of human habitants. In addition, the influence of such extensive land use on the ecosphere requires further investigation.

1.5.2.1 Solar Spectrum The wavelengths of the electromagnetic spectrum of solar energy ranges from 0.2 to $2.5 \mu\text{m}$ (<http://www.esru.strath.ac.uk/Courseware/Class-16110/>). The solar spectrum is shown in Figure 1.13. Note that one angstrom (1 \AA) corresponds to 10^{-8} cm or 10^{-10} m). The sun emits radiation in the ultraviolet, visible, and near-infrared regions. Due to the existence of ozone layer in the atmosphere, the ultraviolet photons are absorbed by this region with the result we observe only the visible radiation in the region of 4000 \AA to 8000 \AA on earth.

1.5.2.2 How Do We Convert the Solar Radiation to Electricity? During the 19th century, the race was on for understanding the composition and structure of matter. This race led us to our current understanding of atomic structure—namely that atoms contains electrons, protons, and neutrons. During the course of this race, Albert Einstein

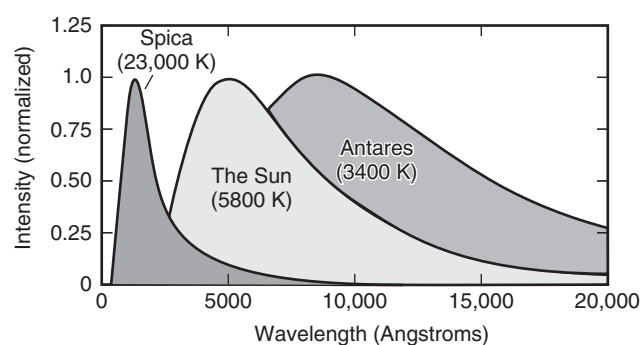

Figure 1.13 Solar spectrum. [Reproduced with permission from <http://csep10.phys.utk.edu/astr162/lect/sun/spectrum.html>.]

discovered a phenomenon called the photoelectric effect. He focused a beam of photons onto a low work function metal such as selenium metal and collected the electrons ejected out of the metal. This experiment may be considered as the starting point for the development of solar cells.

Solar cells are of two types: photovoltaic and photoelectrochemical. The photovoltaic is completely a solid state device and is made up of two different semiconductors. The photoelectrochemical solar cell uses a semiconductor in a liquid electrolyte. These two types are discussed below.

1.5.2.3 Photovoltaic Cells Materials such as silicon, germanium, and compounds of II-V and II-VI elements in the periodic table exhibit a property of semi-conduction and are called semiconductors. These semiconductors have electrical conductivity lower than metals and higher than insulators. Silicon is an ideal one for our discussion as it is a cheap material for fabrication of photovoltaic cells. When pure silicon is doped with an acceptor element such as boron, it becomes a positively charged (p-type) semiconductor. On the other hand, when it is doped with a donor element such as phosphorus, it becomes a negatively charged (n-type) semiconductor. We will take the example of silicon. Here silicon has a valency of four and each silicon atom is bonded to four other silicon atoms as shown in Figure 1.14. When it is doped with boron that has a valency of three, silicon is replaced with boron as shown in Figure 1.15.

Boron does not have the necessary number of electrons to form bonds with silicon. Hence it leaves a hole and such a semiconductor is a p-type semiconductor or boron doped silicon. Any atom that has a deficient number of electrons will produce this effect. For example, instead of boron, aluminum, indium, or gallium can be used. Donor levels are in the range of 1 in 10^6 or less. The situation is different when silicon is phosphorus doped. Phosphorus has a valency of five and replacement of a silicon by phosphorus results in the structure depicted in Figure 1.16. One valence electron of phosphorus is free and is available for conduction. The phosphorus atom is negatively charged and hence is defined as the n-doped semiconductor or phosphorus doped silicon. The illustrations in the figures indicate how the n- and p-type semiconductors are formed. The doping levels will decide

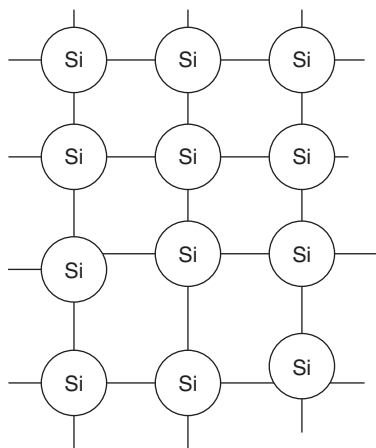

Figure 1.14 Intrinsic semiconductor.

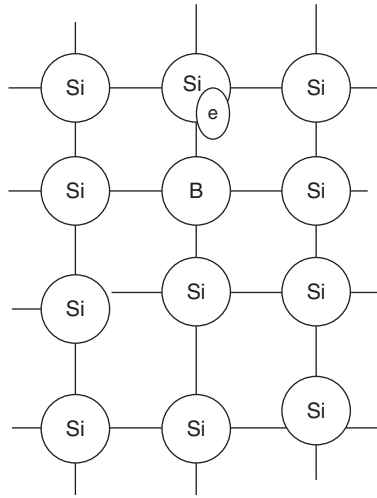

Figure 1.15 Boron doped semiconductor.

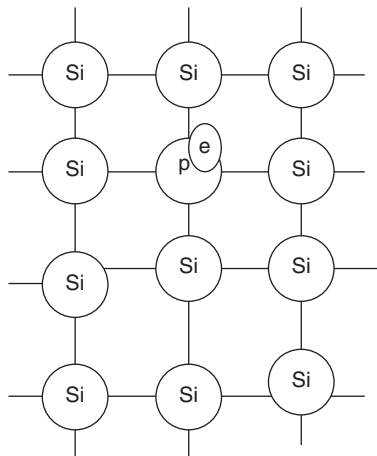

Figure 1.16 Phosphorus-doped silicon.

the number of phosphorus atoms in silicon or boron atoms in silicon. The doping can be done to a high level to make a semiconductor into a metal.

Let us consider a case of combining an n-type semiconductor and p-type semiconductor as shown in Figure 1.17. It is called p-n diode. This diode is connected to a battery supply where a positive terminal of the battery is connected to the p-type silicon and negative terminal to the n-type silicon. Under the above conditions (called the forward bias), p-Si is made more positive such that the electron movement occurs from the left to right. An electron can move across the junction and is a downhill process. An electron can fill in the hole in this biasing conditions. The conduction direction for the electron is from right to left. Under reverse bias conditions, the p-silicon is made negative such that it is harder for the electrons to move across the junction. The flow of electrons and holes in the forward bias condition is shown in Figure 1.18. White circles are holes and black circles are electrons

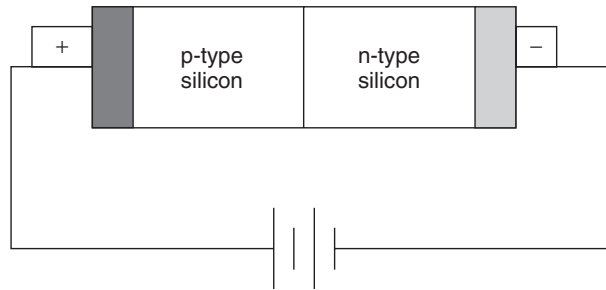

Figure 1.17 p-n Diode with forward bias.

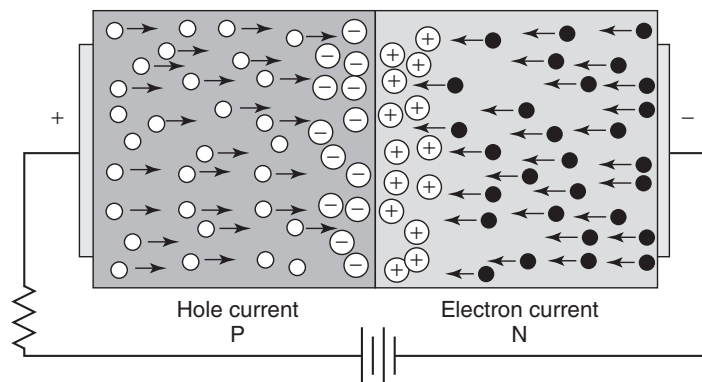

Figure 1.18 Electron and hole flow in the forward bias condition. [Reproduced with permission from Wikipedia.]

in the diagram. When an electron crosses over the junction, electron-hole recombination occurs, shown in the figure by a circle with minus sign. The current that flows at different applied voltages can be monitored and Figure 1.19 is a typical curve for the forward bias conditions.

1.5.2.4 Solar Cells A solar cell is based on the photovoltaic effect that was first discovered by Alexandre Edmond Becquere in 1839. The first solar cell was constructed in 1883 by using selenium and gold. It produced an efficiency of 1%. Subsequently, solar cells were constructed using a p-type semiconductor and an n-type semiconductor as discussed in the previous section. When solar radiation falls on the p-n device, charge carriers are generated that results in the conversion of solar photons into electricity. The band gap of the semiconductor absorbing the radiation is an important factor for this conversion. Silicon is ideal as its band gap energy is about 0.60 eV and a large part of the solar radiation will be effective in producing electricity.

A solar cell is primarily converting the incident photons to electricity. Figure 1.20 shows a single solar cell, a solar module made of several solar cells connected together, and a solar array panel where several modules are connected together. There are three generations of solar cells developed so far. Each of the generations has been aimed at improving the conversion efficiency. In the first generation of solar cells, the efficiency (defined as photons to electricity) was about 5–6% using silicon. This was increased to 30% in the

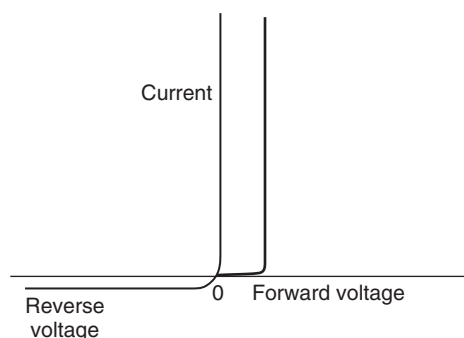

Figure 1.19 Current flow under forward and reverse bias conditions. For silicon the current flow starts at about 0.5 V and gives very high currents at 0.7 V.

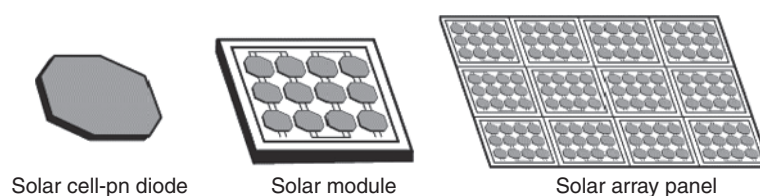

Figure 1.20 Solar panels used for conversion of sunlight to direct current (DC electricity).

most efficient multiple junction solar cells in the third generation. The first generation is made of a large area single-layer p-n junction diode; it is useful in producing electricity from the incident radiation. In the second generation solar cells, multiple layers of p-n junction diodes were developed. With these solar cells, longer wavelength radiations are also utilized, resulting in higher conversion efficiency. With the third generation solar cells, a light-absorbing material is added onto the solar cell. These light-absorbing materials are dyes, organic polymers, and quantum dots. Today, solar cells can give an efficiency of 30% with semiconductors such as gallium arsenide or indium selenide.

1.5.2.5 Photoelectrochemical Solar Cells The sun's radiation has been successfully used to a) generate electricity by using photoelectrolytic cells, b) produce a good fuel such as hydrogen, c) produce chemicals that are less expensive, and d) convert plant carbohydrates into more useful liquid fuel such as alcohol. These methods are depicted diagrammatically in Figure 1.21. Where the methodology of utilization of solar energy is described in column 1, and the material absorbing the solar radiation is shown in column 2. The third column gives a pictorial representation of the method. The interface that produces the output in the method is shown under the column "interface." In the last column, the nature of the output upon solar radiation striking the interface is given. For example, the solar radiation falling on a semiconductor that is placed inside an electrolytic solution is electrical and hence this method is called the photoelectrolytic cell. This method is analogous to the solar cell we discussed in Photovoltaic Cells. In all the methods other than the photoelectrolytic method, the output is chemical. For example, we could decompose water to hydrogen gas, which is called photoelectrosynthesis. In the photocatalytic and photobiological methods shown in Figure 1.21. In these methods, chemicals absorb the

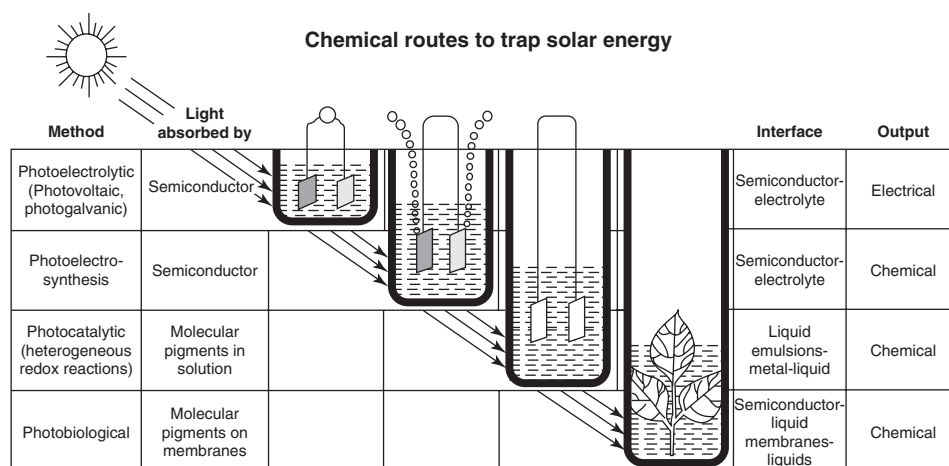

Figure 1.21 Chemical routes for solar energy.

solar radiation and transfer the energy until it is stored in stable molecules. A few details regarding these methods are discussed in the following sections.

1.5.2.6 Photoelectrolytic Cells In the photoelectrolytic pathway to generate electricity from sunlight, two types of devices have been developed. Photovoltaic (liquid-junction solar cells that differ from solid state solar cells) and photogalvanic devices. With the liquid junction photovoltaic cell, the device is made up of a semiconductor electrode and a metal electrode. When solar radiation strikes the semiconductor, electrons are excited from the valence band to the conduction band leaving a vacancy, called the hole, in the valence band. The electrons in the conduction band move through the external circuit resulting in the flow of current. The hole that has been created by the absorption of radiation oxidizes a species in solution. In general, in aqueous solutions, oxidation of water to oxygen occurs at this electrode. Simultaneously at the counter electrode a reduction process occurs. The flow of electrons that occurs upon excitation of the semiconductor is the photocurrent.

In a normal semiconductor, energy gradients do not exist and hence the excited electron recombines with the hole so fast that it is very difficult to bring about the separation of the charges (electron and hole). Hence it is very difficult to drive chemical reactions on its surface. This situation changes dramatically when it is placed in an electrolytic solution. The charge separation occurs because of the space-charge region underneath the surface with the electrolyte (see Figure 1.22) that is present in this situation, promoting the chemical reactions to occur on the surface of the semiconductor. Note that in Figure 1.22 the conduction and valence bands are bent near the electrode-solution region (this is called band bending). The atoms of the semiconductor near the electrolyte solution have higher energies relative to the bulk of the semiconductor. These cases are shown for n- and p-type semiconductors in Figure 1.22. The electrons and holes on the surface can react with different redox systems. This, however, is based on the energetics of the redox reactions.

1.5.2.7 Photoelectrosynthetic Cells The decomposition of water by using solar radiation is a difficult process. We know from our practical experience that leaving a bucket

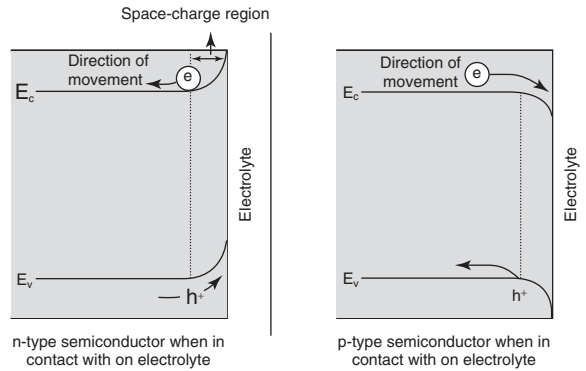
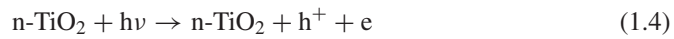

Figure 1.22 Space charge regions when n- or p-type semiconductors are in contact with an electrolyte.

of water in sunlight does not result in the splitting of it into hydrogen and oxygen. However, the situation changes when the bucket of water contains a semiconductor such as n-type titanium dioxide. It decomposes to hydrogen. This occurs due to absorption of solar radiation by the semiconductor, resulting in the electron and hole generation. This decomposition of water to hydrogen and oxygen was reported in 1970 by Fujishima and Honda, who collected 11 liters of hydrogen on a good Japanese summer day using a single crystal of n-titanium dioxide electrode and a platinum counter electrode. This electrochemical cell worked with an efficiency of 0.4%. This result is quite impressive as the titanium dioxide absorbed only 4% of the solar radiation that is incident on it.

Photoelectrosynthetic cell is a device that drives an uphill chemical reaction using a solar energy photons so that solar energy is stored in the chemical; uphill meaning requires external energy to be given to the system for decomposition. In the above example, water decomposition to hydrogen and oxygen is an uphill process—solar energy is able to drive it using a semiconductor. The first step is a process of absorption of solar energy of appropriate wavelength being absorbed by the semiconductor (n-TiO₂ absorbs radiation with energies greater than about 3.2 eV—bandgap energy of the semiconductor)



where h^+ is a hole and e is the electron. This is followed by

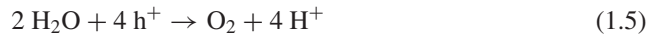

and



Over the years, several improvements were made in the materials used for solar energy absorption. Using silicon dioxide or magnesium oxide doped iron oxide as the electrode for solar energy absorption, and sodium sulfate or sodium hydroxide as the electrolyte, four liters of hydrogen per hour could be produced for a square meter of the electrode. Recently, nanosized semiconductor particles have been used in photoelectrosynthetic cells.

1.5.2.8 Photocatalytic Cells Solar energy can be successfully utilized for driving a chemical reaction using a catalyst. By this method, several useful chemicals can be produced at a faster rate. Ammonia synthesis from nitrogen and hydrogen is one example. Using zinc doped p-gallium phosphide, this reaction occurs spontaneously with the help of photons. The production of aromatic compounds at semiconductor particles and at colloidal particles is an interesting example of this type.

1.5.2.9 Photobiological Systems Photosynthesis that occurs in plants every day is an example of this category. Photobiological systems seek to mimic the complex photosynthetic processes in plants. With photosynthesis, carbon dioxide and water combine to produce carbohydrates. If the synthesis continues all the way to produce hydrocarbons, then it can be a useful energy source. It does occur in some plants such as rubber tree (Havea). These plants belong to the family of Euphoribiceae.

Nobel laureate Melvin Calvin suggested that green plant chloroplasts could be used as a model to understand efficient ways of capturing and storing solar energy. Figure 1.23 gives the energy cycle where the arrows on the left of the tree shows the photosynthesis in the tree producing the leaves. Solar energy is now stored in the green leaves. Bacterial action on decaying plant matter in the absence of oxygen and in the presence of silt and water produces coal. This occurs after a long time and millions of years of bacterial action under pressure. The first step in this decay is the formation of peat-compressed plant matter that contains twigs and leaves. The subsequent step is the formation of brown coal or lignite, followed by the formation of bituminous coal. This coal is used in the thermal power reactors to produce electricity and that is shown on the right side of Figure 1.23. In this energy cycle, solar energy is ultimately converted into electricity.

1.5.2.10 Solar Heater Solar energy is used for heating water for domestic and industrial purposes. Swimming pools in several countries are heated by solar heaters. This requires the usage of solar thermal collectors. In several European and Asian countries, a very high percentage (up to 75%) of domestic hot water supply comes by this method.

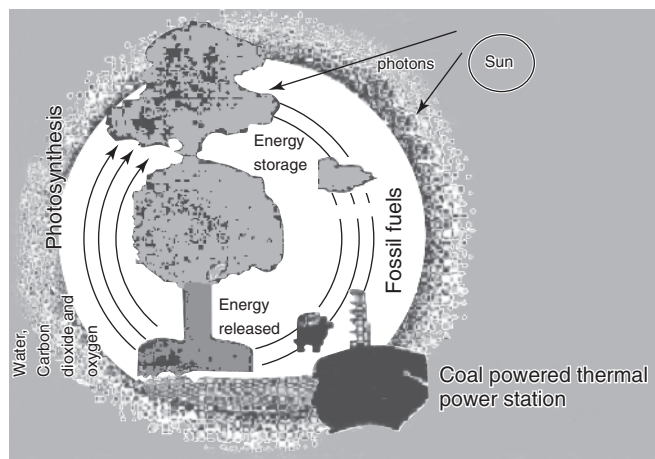

Figure 1.23 Photosynthetic energy cycles.

1.5.2.11 Solar Cooker A thermally insulated box that traps solar energy has been successfully used for cooking food. In India, chappatis (Indian bread) are made in desert areas by using this type of box. In the developed countries it is used for pasteurization and fruit canning.

1.5.2.12 Solar Pond Differential salt concentration causes density gradients that restrict the heat exchange by natural convection. By filling a pond with three layers of water containing three different concentrations of salt, with the top layer having the lowest concentration and the bottom layer having the highest concentration of salt, solar energy is trapped in the bottom layers. This approach is particularly useful for rural areas for heating buildings or generating electricity.

1.5.2.13 Solar Energy for Splitting Water In recent years, experiments have been carried out to split water into hydrogen by concentrating sunlight through several stages and focusing with fiber optics. This method is discussed in detail in Chapter 2.

1.5.3 Geothermal Energy

Subterranean planetary activity continually generates and stores an enormous energy resource as heat. Geothermal energy from the earth's internal heat can be extracted and used to generate electricity for heating homes and businesses. Geothermal energy can be found in the earth's crust, or lithosphere, in tectonically active regions. The most accessible regions of the lithosphere are thin or have been disrupted by recent (10 million years or less) volcanic or earthquake activity. There are four types of geothermal resources: hydrothermal systems, geo-pressured zones, hot and dry rocks, and magma from the earth's core.

Hydrothermal systems are found where groundwater has seeped down into the earth along the fault lines and becomes heated by hot rock. The high-pressure conditions that are found deep below the earth's surface can heat and store hot water at temperatures well above the boiling point of water on the surface. As heated groundwater moves down through rock fractures, it eventually pools in reservoirs, where it may rise back to the surface through natural convection processes. These hydrothermal reservoirs have temperatures ranging from 250 to 600°F and are the source of the earth's natural hot springs and geysers (Figure 1.24). Hot water vaporizes into steam as it nears the lower pressures at the surface. Steam is separated and used to power turbines that generate electricity. The hot water component, which has a lower temperature than the steam, is processed through a binary plant to generate electricity (Figure 1.25).

Geo-pressured zones are subsurface areas where saltwater, or brine, becomes trapped between layers of hot, impermeable rock. The brine reaches temperatures of 200–400°F and becomes very highly pressurized. This reservoir of heat and hydraulic pressure can be tapped to generate electricity. Sometimes dissolved methane can be found in large quantities within the brine, increasing the potential energy resource.

Hot and dry rocks can be found everywhere among the lithosphere, making it a potentially plentiful geothermal resource on a global scale. However, this type of solid rock is found at depths greater than two miles beneath the earth's surface and where there is no liquid to carry the heat. To tap this energy, man-made wells are drilled, into which water is pumped under high pressure to create fracture networks among the heated rocks. The circulating water absorbs the heat from the rock and creates hydrothermal reservoirs. Once

the water reaches high enough temperatures, it can be pumped back to the surface and used to generate electricity.

Magma or molten rock from the earth's mantle and lower crust is what generates the volcanic activity. Most magma originates at depths of 20 miles or more, but in some global regions—near volcanoes and mid-ocean ridges—significant amounts of magma may also be found closer to the surface. These magma reservoirs, or calderas, can be tapped for their geothermal energy. Extracting the energy from magma requires well-drilling equipment that can reach to great depths—with some drilling locations at the bottom of the ocean—and withstand temperatures above 2000°F. The technology of this magnitude is still in development. Typically, water is pumped into the well to solidify the magma and acts as a heat exchanger to further generate electricity. The other possibility is to mix water directly with the iron oxide in the magma to generate hydrogen. The collected hydrogen by-product can be burned to generate energy.

Geothermal heat pump systems make use of the constancy of temperature found in the shallow ground, less than 10 feet below the surface. These systems are for direct-use applications and can be used to generate heating, air conditioning, and hot water in buildings. The pumps have three basic parts: the ground heat exchanger, the heat pump unit, and ductwork to deliver the heated or cooled air. The heat exchanger is a loop of pipe that is buried in shallow ground near the building. A mixture of water and antifreeze is circulated through the pipe, either absorbing or releasing heat within the ground. In the winter, the pump draws heat from the warmer ground and transfers it to the building, and in the summer it removes heated air from the building and releases it within the ground.

Geothermal energy is a clean, efficient (see Figures 1.24 and 1.25), and abundant heat source for small, end-user applications, such as district heating systems, space heating, industrial heating, greenhouses, agriculture and livestock farms, aquaculture, seawater distilleries, and organic drying facilities.

1.5.4 Biomass Energy

Any organic material made from plants or animals is considered biomass. Energy from the sun is stored in plants via photosynthesis in the form of chemical energy. The plant-eating animals (including people) absorb this chemical energy. When biomass is burned, the stored chemical energy can be released. It can also be converted to other usable energy forms, such as methane gas, ethanol, biodiesel fuel, and biogases. The conversion processes used are anaerobic digestion, gasification, and fermentation that take place in biorefineries,



Figure 1.24 Geothermal energy hot springs in Bridgeport, CA. [Reproduced with permission from Wikipedia.]

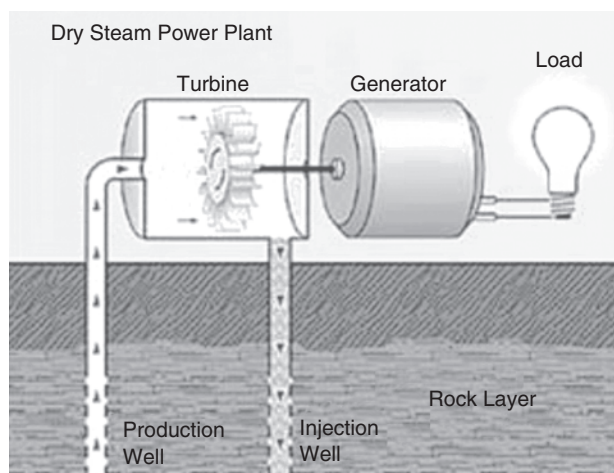

Figure 1.25 Geothermal Energy. [Reproduced from National Renewable Energy Laboratory (NREL).]

similar to oil refineries and petrochemical plants. However, the biomass industry worldwide uses a diverse scale of conversion processes that are dependent upon the variety of feedstock available in a particular region.

Biomass energy can be produced from wood, food crops (Figure 1.26), grasses, forestry by-products (such as sawdust), agricultural by-products (such as peanut hulls), manure, and other organic municipal solid wastes (MSW). Wood is currently the most common form of biomass used.

There are three types of biomass energy applications: biopower, biofuels, and bioproducts. Biopower is the heat and electricity generated by burning biomass directly or converting it into biogases (methane) or liquid fuels that burn. Raw wood is used for fuel, as well as wood fuel pellets that have a greater energy density. Pellets are made by compressing sawdust, wood shavings, and paper into small cylinders that have low moisture content. In addition to compressed wood waste, fuel pellets can be made from agricultural waste such as ground peanut hulls, straw, corn, and rice husks. They are easily stored and transported, plus they are a clean, efficient way of utilizing the by-products from local forestry and agricultural industries. Solid-waste landfills are full of potential biopower. As organic matter decomposes, a mixture of methane gas and carbon dioxide is released. The methane gas can be recovered and used to produce electricity. Additionally, the mineral-rich residue from the gasification process is a sludge that can be collected and sold as fertilizer. Biofuels are liquid fuels, such as ethanol and biodiesel, which are used for transportation. They can be used on their own or blended with gasoline and diesel fuel. Biofuels burn cleaner and produce fewer air pollutants. Ethanol is produced in the fermentation process that extracts the glucose from corn, wheat, rice, potatoes, beets, and even yard waste. However, woody crops (such as poplar and willow trees) and switchgrass are emerging as new dedicated crops for making ethanol. Gasoline engines can run on a 15% ethanol–85% gasoline mixture, but fuels that have higher ethanol contents need special vehicles. Biodiesel fuel is distilled from vegetable oils and animal fats that are recycled from restaurant waste grease and sometimes from plant sap. Diesel engines can use biodiesel fuels as a safe, biodegradable fuel that reduces emissions. Biofuel efficiency is currently less than 1%, due to the energy that is expended to grow, fertilize, and harvest the vegetation that makes it.



Figure 1.26 Corn field for ethanol production. [Reproduced from: http://upload.wikimedia.org/wikipedia/en/0/0a/Maize_ear.jpg.]

The use of biomass energy offers many economical and ecological benefits. Most importantly, it has the potential to reduce greenhouse gas emissions in significant amounts because biomass is carbon-neutral. This is because the carbon dioxide released when biomass is burned or converted is equal to the amount of carbon dioxide it absorbed during photosynthesis. Plant tissue also has almost no sulfur content, thereby reducing acid rain when used. Agriculture and forestry industries are supported and enhanced by the use of biomass energies because the feedstocks for power generation come from residues from crops and wood. Biomass energy optimizes land use because feedstock crops can be cultivated on land that is not suitable for food crops and would otherwise be unused. Bioproducts can replace the traditional ones made from petroleum. And biomass energy recycles unused material, which significantly supports the waste management—particularly in large, urban cities like New York.

1.5.5 Hydropower Energy

Of all the renewable energies that generate electricity, hydropower is the most widely used. Hydroelectric power plants harness the mechanical energy in moving water and located on or near a dynamic water source (see Figure 1.27). The water's flow or fall determines the amount of available energy. As the water rushes through a pipe intake, its pressure pushes against turbine blades that spin an electrical generator. The electricity is then transmitted through power lines to a grid. In a storage system, the water remains in a reservoir



Figure 1.27 Hydroelectric power generators at Nagarjuna dam and hydro-electric plant, India. [Reproduced with permission from Wikipedia.]

created by a dam and then is released when electricity demand is high. Hydropower is clean, with no waste products that pollute the water or the air. It does impact the environment when dams interrupt the natural habitat; for instance, fish trying to swim upstream to spawn.

1.5.6 Ocean Energy

The ocean's abundant energy can be captured in the tides, the waves, the deep-ocean currents, and in the warmer surface waters in tropical locales (3). Tidal energy systems harness the power in the tides caused by the sun-moon's gravitational pull and the earth's rotational pull. High- and low-tide pulls can cause near-shore water levels to vary up to 40 feet. A tidal range of 10 feet is needed in an area that has an inlet in order to produce energy that is economically feasible. Tidal energy plants have a dam, or tidal barrage, that stretches across an inlet. The barrage has gates that allow ocean water to fill into a tidal basin during the incoming high tides and to empty on the outgoing tide through a turbine placed within the basin. Tidal fences are another option that can be installed in channels. They are vertical-axis turbines mounted in a fence that forces all tidal water to pass through the turbines. The tidal turbines generate electricity using the same technology as wind turbines. Wave energy systems harness the power in the waves as the wind blows them over the ocean's surface. The world's coastlines are ideal sites to capture wave energy. As waves approach shore, they are "focused" into a narrow channel, which increases their energy power before they are forced through turbines. Ocean thermal energy conversion (OTEC) is a system that extracts the sun's heat from the surface water to produce electricity. In tropical waters, the surface temperature can be 40 or more degrees warmer than the deeper water. These systems are not economical because the electricity that is produced must be transported to land.

Currently at least 48 countries are involved in renewable energy development and utilization. Due to current economic conditions, the need for renewable energy has never been

greater and has demonstrated strong growth within the last decade. In 2004, global investments in renewable have reached over US\$30 billion. More than 1.7 million people are directly employed by the industry and the 160 GW of installed renewables represents 4% of global capacity (9).

1.6 ENERGY STORAGE

The biggest disadvantage of electric power is that electricity cannot be economically stored directly, but it can be stored in other forms that consume a lot of energy for conversion and subsequent distribution. By storing the power during off-peak periods and releasing it at peak times, coinciding with periods of peak consumer demand, energy storage can transform this spontaneous power into schedulable, high-value products. Energy storage in the form of hydrogen can be more effective in comparison to other available energy storage options, which are described below.

1.6.1 Pumped-hydro Storage

Pumped-hydro facilities consist of two large reservoirs; one located at a low level and the other situated at a higher elevation. During off-peak hours, water is pumped from the lower to the upper reservoir, where it is stored. To generate electricity, the water is then released back down to the lower reservoir, passing through hydraulic turbines and generating electrical power. Known applications are limited to powerful energy plants but require substantial real estate for installation.

1.6.2 Compressed Air Energy Storage

Compressed air energy storage systems use off-peak power to pressurize air into reservoirs, which is then released during peak daytime hours to be used in gas turbines for power production. Existing facilities are sized in the range of several hundred megawatts. In a gas turbine, roughly two thirds of the energy produced is used to pressurize the air. The idea is to use low-cost power from an off-peak load facility in place of the more expensive gas turbine-produced power to compress the air for combustion. Since facilities have no need for air compressors tied to the turbines, they can produce two to three times as much power as conventional gas turbines for the same amount of fuel (12) (Baxter, 2002). No technical information or economical data are available for pneumatic energy storing from small sources of renewable energy.

1.6.3 Flow Batteries

Flow batteries, also known as regenerative fuel cells, are capable of storing and releasing energy through a reversible electrochemical reaction between two redox solutions. These are called dissolved redox electrolyte systems (13 & 14)(Chen et al., 1981; 1982). Designs exist around the use of zinc bromide ($ZnBr_2$), vanadium bromide (VBr), and sodium bromide (NaBr) as the electrolytes. Charging of the facility occurs when electrical energy from the grid is converted into potential chemical energy. Release of the potential energy occurs within an electrochemical cell, with a separate compartment for each electrolyte, physically separated by an ion-exchange membrane. The technology is a closed-loop cycle, so

there is no discharge of the regenerative electrolyte solutions from the facility. The scale of the facility is based primarily on the size of the electrolytic tanks.

1.6.4 Batteries

A number of battery technologies exist for use as utility-scale energy storage facilities. Primarily, these installations have been lead-acid, but other battery technologies such as sodium sulfide (Na_2S) and lithium ion are quickly becoming commercially available. All batteries are electrochemical cells. During discharge, ions from the anode are released into the solution and oxides are deposited on the cathode. Reversing the electrical charge through the system recharges the battery. When the cell is being recharged, the chemical reactions are reversed, restoring the battery to its original condition. Cost, environmental issues related to used batteries disposal, and limited number of recharge cycles make this approach not very valuable.

1.6.5 Superconducting Magnetic Energy Storage

Superconducting magnetic energy storage systems store energy in the magnetic field created by the flow of direct current in a coil of cryogenically cooled super-conducting material. A system includes a superconducting coil, a power conditioning system, a cryogenically cooled refrigerator, and a cryostat/vacuum vessel. They are highly efficient at storing electricity (greater than 95%), and provide both real and reactive power. These facilities are used to provide grid stability in a distribution system and power quality at manufacturing plants requiring ultra-clean power, such as microchip fabrication facilities. This technology is still in the development stage and not cost effective for small distribution generation systems.

1.6.6 Supercapacitors

Based on a study the U.S. National Renewable Energy Laboratory conducted in 1997 on a system in Deering, Alaska, the largest fuel saving with supercapacitors (the high energy density electrochemical device, typically on the order of a thousand times greater than an electrolytic capacitor) came from relatively short-term storage. Evidence from this test indicated that a storage capability of 10 minutes reduced the fuel use by 18%, the diesel running time by 19%, and the number of diesel starts by 44%. We believe that short time storage capability making use of supercapacitors a not very attractive option for wind energy storage. However, applications such as peak shaving measure, especially into electric propulsion systems, are becoming an everyday practice.

1.6.7 Flywheels

A flywheel energy storage system works by accelerating a rotor to a very high speed and maintaining the energy in the system as inertial energy. Advanced composite materials are used for the rotor to lower its weight while allowing for the extremely high speeds; energy is stored in the rotor in proportion to its momentum. The flywheel releases the energy by reversing the process and using the motor as a generator. As the flywheel releases its stored energy, the flywheel's rotor slows until it is discharged. In application as energy storage for industrial use, flywheels are limited to shaving peak power for relatively a short term due

to substantial time needed for power charge and discharge. Other limitations are related to safety and cost consideration.

1.6.8 Hydrogen Storage

An attractive method of producing hydrogen gas is through electrolysis of water using a dedicated electrolyzer. The generated hydrogen gas can be coupled to a fuel cell system to produce electricity. However, most often it is preferable to store hydrogen gas and transport it to far off places for subsequent utilization in fuel cells. Hydrogen and oxygen from an electrolyzer may be stored separately in pressure tanks or other hydrogen storage media, such as metal hydrides. Hence the generated hydrogen is an energy carrier that can be transported to any location of use and discharged on set schedule at the required time. The economic benefits of storing the energy in the form of hydrogen are namely an emissions reduction, efficiency of utilization, improvement in the operation conditions, and relative simplicity of energy transportation to required site. (See chapter 3.33)

1.7 ENERGY ETHICS

There are many examples showing that human civilization in its need for energy has had a tremendous impact on our planet. In a few generations, the supply of fossil fuels, which were created in over several hundred million years ago, is predicted to be depleted. The emission of SO_2 into the atmosphere following the combustion of coal and oil is more than from natural sources such as the decomposition of dimethyl sulfide from oceans. The release of NO from the combustion of fossil fuels and biomass is now probably larger than natural sources creating photochemical smog in urbanized areas. “Greenhouse” gases, such as CO_2 and CH_4 , that are often associated with energy production, are contributing to the global warming process. These and other impacts of human activities on the earth’s ecosystem have led to the discussion for defining the current geological period as the “Anthropocene Epoch.”

An energy policy is needed that will promote conservation of energy to minimize the impact on our planet and enable the transition toward sustainable management of the environment at every level of the society—from individual, family, local, national, to international. Individuals, as consumers and members of society, must recognize that there are connections between our consumption choices and the rest of the world. Consumers need to purchase more energy-efficient appliances, homes, and vehicles for long distance single-person trips. Choosing hybrid vehicles with better energy efficiency, locally grown products, installing solar photovoltaic panels, and purchasing green power will help meet future energy needs of society and preserve our environment. Many consumers help save energy by recycling and purchasing recycled materials rather than buying new products.

Governmental policies on taxes, subsidies, incentives, and standards need to be in place to encourage both energy efficiency for automobiles, factories, appliances and homes, and improvement of the environment. In some countries, excellent bike infrastructure and public transportation together with high taxes for vehicle registration have led to the use of bike, subway, or bus rather than car for transportation. The governments with higher energy prices have lower energy needs per capita than countries with lower energy prices.

To ensure the sustainability of human civilization on our planet, society has to concentrate on improving energy efficiency by utilizing alternative sources of energy; one of

them being hydrogen technology. By switching to renewable energy sources and hydrogen technology, we would be able to contribute to sustainable management of the environment.

BIBLIOGRAPHY

1. Available at <http://www.cnn.com/2003/ALLPOLITICS/02/06/bush-energy/index.html>
2. US Government Energy Information Administration available at <http://www.eia.doe.gov/> and <http://wilcoxon.maxwell.insightworks.com/pages/804.html>
3. Accessed Nov. 2007 from <http://www.oceanenergycouncil.com/index.php/Tidal-Energy/Tidal-Energy.html>
4. Accessed Dec. 2006 from <http://www.combussem.com/ENERGY1.HTM>
5. Clerici, A., "World Energy Council Survey of Energy Resources", Presentation, 2004 www.eia.doe.gov
6. Available at <http://www.eia.doe.gov/emeu/cabs/nonopecc.pdf>
7. Oil & Gas Journal, Vol. 102, No. 47, Dec. 20, 2004, last accessed 4/1/2008 from <http://www.ogj.com/currentissue/index.cfm?p=7&v=102&i=47>
8. Available at <http://www.bp.com/home.do?categoryId=1>
9. Martinot, E. Global revolution-A status report on renewable energy worldwide by Renewable Energy World MARCH/APRIL, 2006 Also can be accessed from <http://ngm.nationalgeographic.com/ngm/0508/feature1/text2.html>
10. Crutzen, P.J. available at <http://en.wikipedia.org/wiki/>
11. Rubbia, C., "The Future of Energy", 18th IAEA Fusion Energy Conference, Sorrento, Italy, October 4, 2000
12. Baxter R, "Energy storage: enabling a future for renewables?" Renewable Energy World July-August 2002
13. Chen I.Y.D, Santhanam K.S.V, Bard A.J, Solution redox couple for electrochemical energy storage *J. Electrochem. Soc.*, **128**, 1460 (1981)
14. Chen I.Y.D, Santhanam K.S.V, Bard A.J., Solution redox couples for electrochemical energy storage II; *J. Electrochem. Soc.*, **129**, 61 (1982)
15. Available at <http://geology.about.com/library/weekly/aa080402a.htm>
16. Energy Alternatives Cothran H. book editor Greenhaven Press, San Diego, Ca 2002
17. Parfit M, "Powering The Future" National Geographic, August 2005

