

Contents

Introduction	xiii
Chapter 1 ■ Inventor Face to Face	1
Learning to Use the Dialog Boxes	2
The Open Dialog Box	3
The New File Dialog Box	7
Navigating Inventor's User Interface	8
Make Yourself at Home: Customizing Inventor	18
Project Files	28
Using the Help System	34
Summary	36
Chapter 2 ■ Creating 2D Drawings from 3D Data	37
Drawing Views of a Part	38
Creating Base Views	40
Detailing Drawing Views	55
Adding Dimensions in Inventor	59
Associativity	71
Assembly Drawings	74
Detail Views	75
Presentation Views	77
Summary	79
Chapter 3 ■ Introducing Part Modeling	81
The Concept of Parametric Modeling	82
Sketch Constraints	87
The Extrude Tool	104
The Fillet Tool	108
The Hole Feature	113

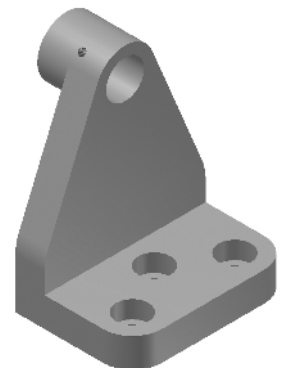
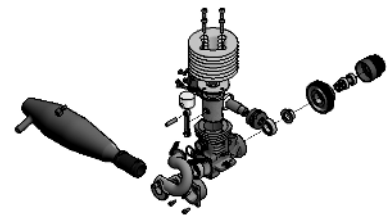
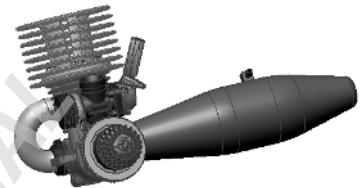

Work Features	120
The Revolve Tool	129
Feature Libraries	134
Summary	136

Chapter 4 ■ Putting It All Together with Assemblies 137

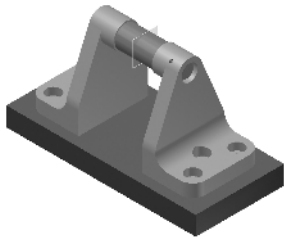

The Assembly Modeling Concept	138
Creating Assembly Constraints	138
Representations	153
Enabled Parts	156
Working with Standard Parts	157
Summary	167

Chapter 5 ■ Standards and Styles 169

Styles and Standards	170
Drawing Templates	185
Summary	193

Chapter 6 ■ Advanced Annotation: Drawing Views and Detailing 195

Moving Beyond the Basic View	196
Expanded Dimensioning Options	210
Summary	227

Chapter 7 ■ Getting in Shape: Advanced Part Modeling 229

A Feature-Rich Application	230
Beginning a New Part	230
The Thread Tool	232
The Split Tool	238
The Emboss Tool	240
Rectangular and Circular Patterns	244
More Sketching Tools	245
The Loft Tool	250
The Sculpt Tool	256



The Shell Tool	262
The Rib and Web Tools	266
The Sweep Tool	268
The Coil Tool	274
The Mirror Tool	278
The Thicken/Offset Tool	284
iParts	286
Summary	292
Chapter 8 ■ Advanced Assembly Tools	293
An Assembly-centric Application	294
Design Accelerators	294
Derived Parts	319
Component Move and Rotate	322
iAssembly	323
Animation within the Assembly	328
Presentation Files	331
Positional Representation	336
Weldments	339
Summary	340
Chapter 9 ■ Introducing Sheet Metal Parts	341
A Manufacturing-Focused Toolset	342
Sheet Metal Rules	342
Making Sheet Metal Parts	350
Sheet Metal Detailing	367
Summary	368
Chapter 10 ■ Introducing Inventor Studio	369
Enhancing Your Design	370
Creating a Rendering	370
Working with Animation	383
Summary	389

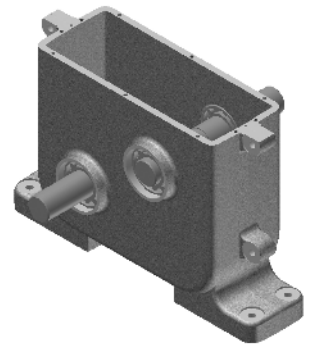

Appendix A ■ Keyboard Shortcut Guide	393
Appendix B ■ Import and Export File Formats	397
Appendix C ■ Additional Resources	399
Index	401