

# 1

## Introduction to protective relaying

### 1.1 What is relaying?

In order to understand the function of protective relaying systems, one must be familiar with the nature and the modes of operation of an electric power system. Electric energy is one of the fundamental resources of modern industrial society. Electric power is available to the user instantly, at the correct voltage and frequency, and exactly in the amount that is needed. This remarkable performance is achieved through careful planning, design, installation and operation of a very complex network of generators, transformers, and transmission and distribution lines. To the user of electricity, the power system appears to be in a steady state: imperturbable, constant and infinite in capacity. Yet, the power system is subject to constant disturbances created by random load changes, by faults created by natural causes and sometimes as a result of equipment or operator failure. In spite of these constant perturbations, the power system maintains its quasi-steady state because of two basic factors: the large size of the power system in relation to the size of individual loads or generators, and correct and quick remedial action taken by the protective relaying equipment.

Relaying is the branch of electric power engineering concerned with the principles of design and operation of equipment (called 'relays' or 'protective relays') that detects abnormal power system conditions, and initiates corrective action as quickly as possible in order to return the power system to its normal state. The quickness of response is an essential element of protective relaying systems – response times of the order of a few milliseconds are often required. Consequently, human intervention in the protection system operation is not possible. The response must be automatic, quick and should cause a minimum amount of disruption to the power system. As the principles of protective relaying are developed in this book, the reader will perceive that the entire subject is governed by these general requirements: correct diagnosis of trouble, quickness of response and minimum disturbance to the power system. To accomplish these goals, we must examine all possible types of fault or abnormal conditions which may occur in the power system. We must analyze the required response to each of these events, and design protective equipment which will provide such a response. We must further examine the possibility that protective relaying equipment itself may fail to operate correctly, and provide for a backup protective function. It should be clear that extensive and sophisticated equipment is needed to accomplish these tasks.

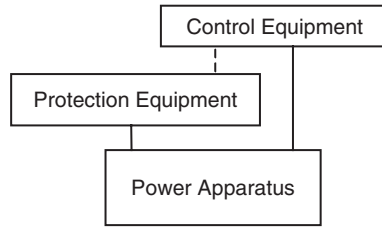

**Figure 1.1** Three-layered structure of power systems

## 1.2 Power system structural considerations

### 1.2.1 Multilayered structure of power systems

A power system is made up of interconnected equipment which can be said to belong to one of three layers from the point of view of the functions performed. This is illustrated in Figure 1.1.

At the basic level is the power apparatus which generates, transforms and distributes the electric power to the loads. Next, there is the layer of control equipment. This equipment helps maintain the power system at its normal voltage and frequency, generates sufficient power to meet the load and maintains optimum economy and security in the interconnected network. The control equipment is organized in a hierarchy of its own, consisting of local and central control functions. Finally, there is the protection equipment layer. The response time of protection functions is generally faster than that of the control functions. Protection acts to open and close circuit breakers, thus changing the structure of the power system, whereas the control functions act continuously to adjust system variables, such as the voltages, currents and power flow on the network. Oftentimes, the distinction between a control function and a protection function becomes blurred. This is becoming even more of a problem with the recent advent of computer-based protection systems in substations. For our purposes, we may arbitrarily define all functions which lead to operation of power switches or circuit breakers to be the tasks of protective relays, while all actions which change the operating state (voltages, currents, power flows) of the power system without changing its structure to be the domain of control functions.

### 1.2.2 Neutral grounding of power systems

Neutrals of power transformers and generators can be grounded in a variety of ways, depending upon the needs of the affected portion of the power system. As grounding practices affect fault current levels, they have a direct bearing upon relay system designs. In this section, we will examine the types of grounding system in use in modern power systems and the reasons for each of the grounding choices. Influence of grounding practices on relay system design will be considered at appropriate places throughout the remainder of this book.

It is obvious that there is no ground fault current in a truly ungrounded system. This is the main reason for operating the power system ungrounded. As the vast majority of faults on a power system are ground faults, service interruptions due to faults on an ungrounded system are greatly reduced. However, as the number of transmission lines connected to the power system grows, the capacitive coupling of the feeder conductors with ground provides a path to ground, and a ground fault on such a system produces a capacitive fault current. This is illustrated in Figure 1.2(a). The coupling capacitors to ground  $C_0$  provide the return path for the fault current. The interphase capacitors  $\frac{1}{3}C_1$  play no role in this fault. When the size of the capacitance becomes sufficiently large, the capacitive ground fault current becomes self-sustaining, and does not clear by itself. It then becomes

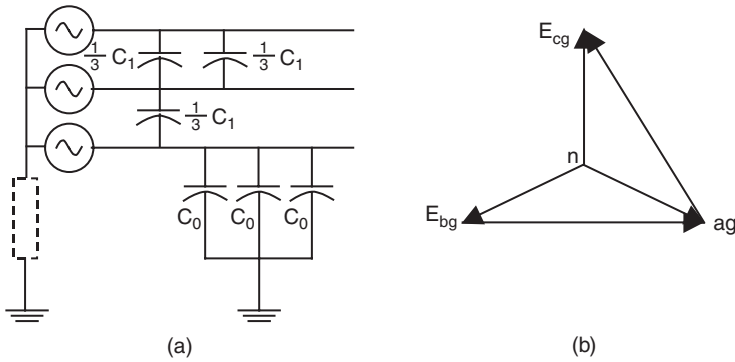

**Figure 1.2** Neutral grounding impedance. (a) System diagram. (b) Phasor diagram showing neutral shift on ground fault

necessary to open the circuit breakers to clear the fault, and the relaying problem becomes one of detecting such low magnitudes of fault currents. In order to produce a sufficient fault current, a resistance is introduced between the neutral and the ground – inside the box shown by a dotted line in Figure 1.2(a). One of the design considerations in selecting the grounding resistance is the thermal capacity of the resistance to handle a sustained ground fault.

Ungrounded systems produce good service continuity, but are subjected to high overvoltages on the unfaulted phases when a ground fault occurs. It is clear from the phasor diagram of Figure 1.2(b) that when a ground fault occurs on phase *a*, the steady-state voltages of phases *b* and *c* become  $\sqrt{3}$  times their normal value. Transient overvoltages become correspondingly higher. This places additional stress on the insulation of all connected equipment. As the insulation level of lower voltage systems is primarily influenced by lightning-induced phenomena, it is possible to accept the fault-induced overvoltages as they are lower than the lightning-induced overvoltages. However, as the system voltages increase to higher than about 100 kV, the fault-induced overvoltages begin to assume a critical role in insulation design, especially of power transformers. At high voltages, it is therefore common to use solidly grounded neutrals (more precisely ‘effectively grounded’). Such systems have high ground fault currents, and each ground fault must be cleared by circuit breakers. As high-voltage systems are generally heavily interconnected, with several alternative paths to load centers, operation of circuit breakers for ground faults does not lead to a reduced service continuity.

In certain heavily meshed systems, particularly at 69 kV and 138 kV, the ground fault current could become excessive because of very low zero sequence impedance at some buses. If ground fault current is beyond the capability of the circuit breakers, it becomes necessary to insert an inductance in the neutral in order to limit the ground fault current to a safe value. As the network Thévenin impedance is primarily inductive, a neutral inductance is much more effective (than resistance) in reducing the fault current. Also, there is no significant power loss in the neutral reactor during ground faults.

In several lower voltage networks, a very effective alternative to ungrounded operation can be found if the capacitive fault current causes ground faults to be self-sustaining. This is the use of a Petersen coil, also known as the ground fault neutralizer (GFN). Consider the symmetrical component representation of a ground fault on a power system, which is grounded through a grounding reactance of  $X_n$  (Figure 1.3). If  $3X_n$  is made equal to  $X_{c0}$  (the zero sequence capacitive reactance of the connected network), the parallel resonant circuit formed by these two elements creates an open circuit in the fault path, and the ground fault current is once again zero. No circuit breaker operation is necessary upon the occurrence of such a fault, and service reliability

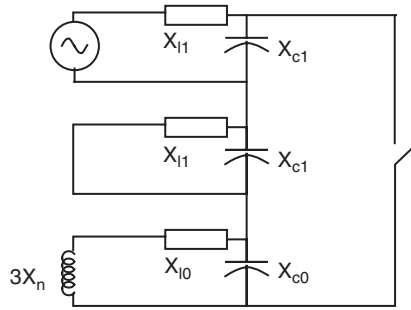

**Figure 1.3** Symmetrical component representation for ground fault with grounding reactor

is essentially the same as that of a truly ungrounded system. The overvoltages produced on the unfaulted conductors are comparable to those of ungrounded systems, and consequently GFN use is limited to system voltages below 100 kV. In practice, GFNs must be tuned to the entire connected zero sequence capacitance on the network, and thus if some lines are out of service, the GFN reactance must be adjusted accordingly. Petersen coils have found much greater use in several European countries than in the USA.

### 1.3 Power system bus configurations

The manner in which the power apparatus is connected together in substations and switching stations, and the general layout of the power network, has a profound influence on protective relaying. It is therefore necessary to review the alternatives, and the underlying reasons for selecting a particular configuration. A radial system is a single-source arrangement with multiple loads, and is generally associated with a distribution system (defined as a system operating at voltages below 100 kV) or an industrial complex (Figure 1.4).

Such a system is most economical to build; but from the reliability point of view, the loss of the single source will result in the loss of service to all of the users. Opening main line reclosers or other sectionalizing devices for faults on the line sections will disconnect the loads downstream of

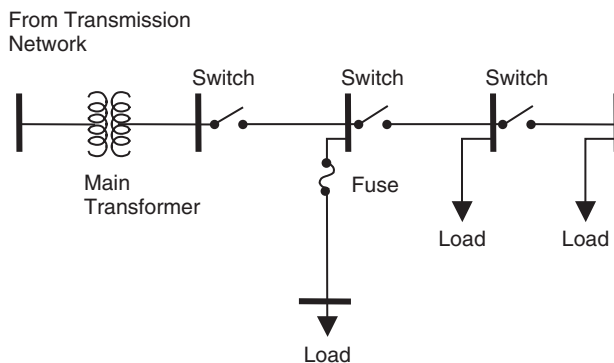

**Figure 1.4** Radial power system

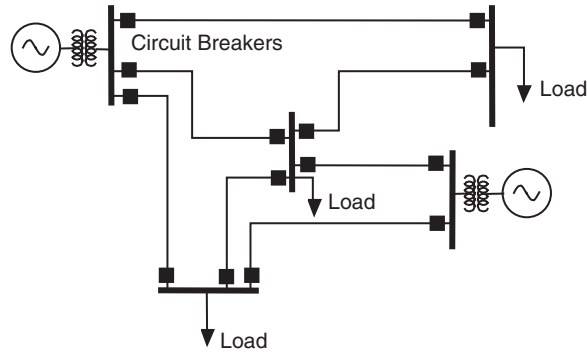

**Figure 1.5** Network power system

the switching device. From the protection point of view, a radial system presents a less complex problem. The fault current can only flow in one direction, i.e. away from the source and towards the fault. Since radial systems are generally electrically remote from generators, the fault current does not vary much with changes in generation capacity.

A network has multiple sources and multiple loops between the sources and the loads. Sub-transmission and transmission systems (generally defined as systems operating at voltages of 100–200 kV and above) are network systems (Figure 1.5).

In a network, the number of lines and their interconnections provide more flexibility in maintaining service to customers, and the impact of the loss of a single generator or transmission line on service reliability is minimal. Since sources of power exist on all sides of a fault, fault current contributions from each direction must be considered in designing the protection system. In addition, the magnitude of the fault current varies greatly with changes in system configuration and installed generation capacity.

**Example 1.1**

Consider the simple network shown in Figure 1.6. The load at bus 2 has secure service for the loss of a single power system element. Further, the fault current for a fault at bus 2 is  $-j20.0$  pu when

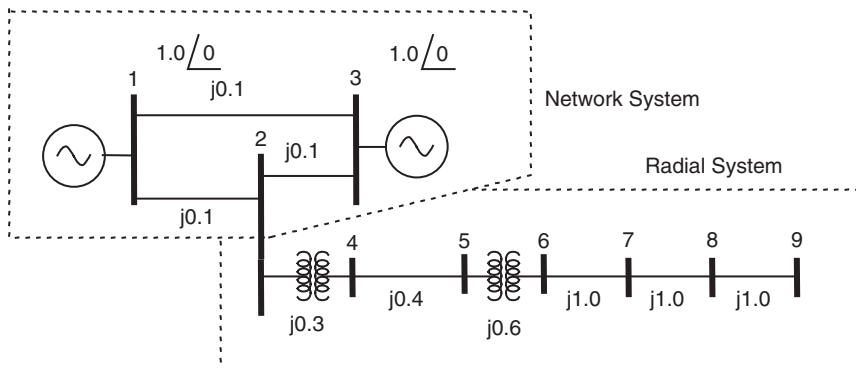

**Figure 1.6** Power system for Example 1.1

all lines are in service. If line 2–3 goes out of service, the fault current changes to  $-j10.0$  pu. This is a significant change.

Now consider the distribution feeder with two intervening transformers connected to bus 2. All the loads on the feeder will lose their source of power if transformer 2–4 is lost. The fault current at bus 9 on the distribution feeder with system normal is  $-j0.23$  pu, whereas the same fault when one of the two generators on the transmission system is lost is  $-j0.229$  pu. This is an insignificant change. The reason for this of course is that, with the impedances of the intervening transformers and transmission network, the distribution system sees the source as almost a constant impedance source, regardless of the changes taking place on the transmission network.

Substations are designed for reliability of service and flexibility in operation, and to allow for equipment maintenance with a minimum interruption of service. The most common bus arrangements in a substation are (a) single bus, single breaker, (b) two bus, single breaker, (c) two bus, two breakers, (d) ring bus and (e) breaker-and-a-half. These bus arrangements are illustrated in Figure 1.7.

A single-bus, single-breaker arrangement, shown in Figure 1.7(a), is the simplest, and probably the least costly to build. However, it is also the least flexible. To do maintenance work on the bus, a breaker, or a disconnect switch, de-energizing the associated transmission lines is necessary. A two-bus, single-breaker arrangement, shown in Figure 1.7(b), allows the breakers to be maintained without de-energizing the associated line. For system flexibility, and particularly to prevent a bus fault from splitting the system too drastically, some of the lines are connected to bus 1 and some to bus 2 (the transfer bus). When maintaining a breaker, all of the lines that are normally connected to bus 2 are transferred to bus 1, the breaker to be maintained is bypassed by transferring its line to bus 2 and the bus tie breaker becomes the line breaker. Only one breaker can be maintained at a time. Note that the protective relaying associated with the buses and the line whose breaker is

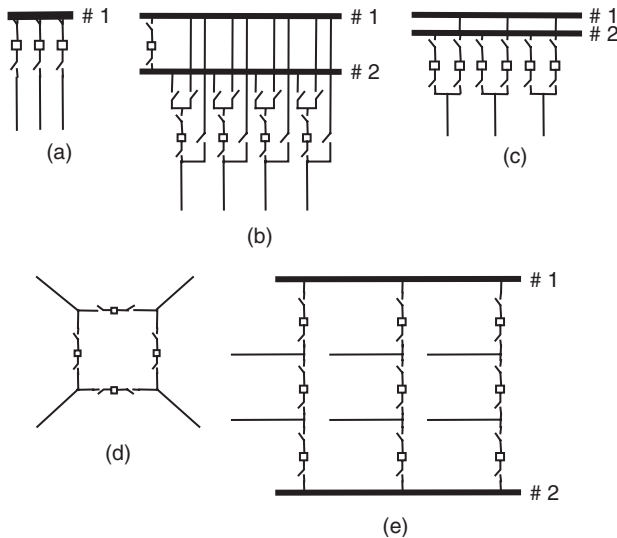

**Figure 1.7** Substation bus arrangements: (a) single bus, single breaker; (b) two bus, one breaker; (c) two bus, two breaker; (d) ring bus; (e) breaker-and-a-half

being maintained must also be reconnected to accommodate this new configuration. This will be covered in greater detail as we discuss the specific protection schemes.

A two-bus, two-breaker arrangement is shown in Figure 1.7(c). This allows any bus or breaker to be removed from service, and the lines can be kept in service through the companion bus or breaker. A line fault requires two breakers to trip to clear a fault. A bus fault must trip all of the breakers on the faulted bus, but does not affect the other bus or any of the lines. This station arrangement provides the greatest flexibility for system maintenance and operation; however, this is at a considerable expense: the total number of breakers in a station equals twice the number of the lines. A ring bus arrangement shown in Figure 1.7(d) achieves similar flexibility while the ring is intact. When one breaker is being maintained, the ring is broken, and the remaining bus arrangement is no longer as flexible. Finally, the breaker-and-a-half scheme, shown in Figure 1.7(e), is most commonly used in most extra high voltage (EHV) transmission substations. It provides for the same flexibility as the two-bus, two-breaker arrangement at the cost of just one-and-a-half breakers per line on an average. This scheme also allows for future expansions in an orderly fashion.\*

The impact of system and bus configurations on relaying practices will become clear in the chapters that follow.

## 1.4 The nature of relaying

We will now discuss certain attributes of relays which are inherent to the process of relaying, and can be discussed without reference to a particular relay. The function of protective relaying is to promptly remove from service any element of the power system that starts to operate in an abnormal manner. In general, relays do not prevent damage to equipment: they operate after some detectable damage has already occurred. Their purpose is to limit, to the extent possible, further damage to equipment, to minimize danger to people, to reduce stress on other equipment and, above all, to remove the faulted equipment from the power system as quickly as possible so that the integrity and stability of the remaining system is maintained. The control aspect of relaying systems also helps return the power system to an acceptable configuration as soon as possible so that service to customers can be restored.

### 1.4.1 Reliability, dependability and security

Reliability is generally understood to measure the degree of certainty that a piece of equipment will perform as intended. Relays, in contrast with most other equipment, have two alternative ways in which they can be unreliable: they may fail to operate when they are expected to, or they may operate when they are not expected to. This leads to a two-pronged definition of reliability of relaying systems: a reliable relaying system must be dependable and secure.<sup>1</sup> Dependability is defined as the measure of the certainty that the relays will operate correctly for all the faults for which they are designed to operate. Security is defined as the measure of the certainty that the relays will not operate incorrectly for any fault.

Most protection systems are designed for high dependability. In other words, a fault is always cleared by some relay. As a relaying system becomes dependable, its tendency to become less

---

\* The breaker-and-a-half bus configuration is the natural outgrowth of operating practices that developed as systems matured. Even in developing systems, the need to keep generating units in service was recognized as essential and it was common practice to connect the unit to the system through two circuit breakers. Depending on the particular bus arrangement, the use of two breakers increased the availability of the unit despite line or bus faults or circuit breaker maintenance. Lines and transformers, however, were connected to the system through one circuit breaker per element. With one unit and several lines or transformers per station, there was a clear economic advantage to this arrangement. When the number of units in a station increased, the number of breakers increased twice as fast: 1 unit and 2 lines required 4 breakers, 2 units and 2 lines required 6 breakers, etc. It is attractive to rearrange the bus design so that the lines and transformers shared the unit breakers. This gave the same maintenance advantage to the lines, and when the number of units exceeded the number of other elements, reduced the number of breakers required.

secure increases. Thus, in present-day relaying system designs, there is a bias towards making them more dependable at the expense of some degree of security. Consequently, a majority of relay system mis-operations are found to be the result of unwanted trips caused by insecure relay operations. This design philosophy correctly reflects the fact that a power system provides many alternative paths for power to flow from generators to loads. Loss of a power system element due to an unnecessary trip is therefore less objectionable than the presence of a sustained fault. This philosophy is no longer appropriate when the number of alternatives for power transfer is limited, as in a radial power system, or in a power system in an emergency operating state.

---



---

### Example 1.2

Consider the fault  $F$  on the transmission line shown in Figure 1.8. In normal operation, this fault should be cleared by the two relays  $R_1$  and  $R_2$  through the circuit breakers  $B_1$  and  $B_2$ . If  $R_2$  does not operate for this fault, it has become unreliable through a loss of dependability. If relay  $R_5$  operates through breaker  $B_5$  for the same fault, and before breaker  $B_2$  clears the fault, it has become unreliable through a loss of security. Although we have designated the relays as single entities, in reality they are likely to be collections of several relays making up the total protection system at each location. Thus, although a single relay belonging to a protection system may lose security, its effect is to render the complete relaying system insecure, and hence unreliable.

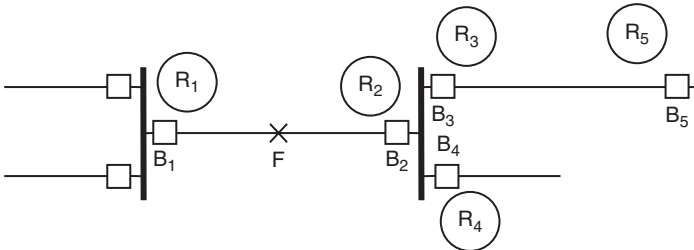

**Figure 1.8** Reliability of protection system

---



---

#### 1.4.2 Selectivity of relays and zones of protection

The property of security of relays, that is, the requirement that they not operate for faults for which they are not designed to operate, is defined in terms of regions of a power system – called zones of protection – for which a given relay or protective system is responsible. The relay will be considered to be secure if it responds only to faults within its zone of protection. Relays usually have inputs from several current transformers (CTs), and the zone of protection is bounded by these CTs. The CTs provide a window through which the associated relays ‘see’ the power system inside the zone of protection. While the CTs provide the ability to detect a fault inside the zone of protection, the circuit breakers (CBs) provide the ability to isolate the fault by disconnecting all of the power equipment inside the zone. Thus, a zone boundary is usually defined by a CT and a CB. When the CT is part of the CB, it becomes a natural zone boundary. When the CT is not an integral part of the CB, special attention must be paid to the fault detection and fault interruption logic. The CT still defines the zone of protection, but communication channels must be used to

implement the tripping function from appropriate remote locations where the CBs may be located. We will return to this point later in section 1.5 where CBs are discussed.

In order to cover all power equipment by protection systems, the zones of protection must meet the following requirements.

- All power system elements must be encompassed by at least one zone. Good relaying practice is to be sure that the more important elements are included in at least two zones.
- Zones of protection must overlap to prevent any system element from being unprotected. Without such an overlap, the boundary between two nonoverlapping zones may go unprotected. The region of overlap must be finite but small, so that the likelihood of a fault occurring inside the region of overlap is minimized. Such faults will cause the protection belonging to both zones to operate, thus removing a larger segment of the power system from service.

A zone of protection may be closed or open. When the zone is closed, all power apparatus entering the zone is monitored at the entry points of the zone. Such a zone of protection is also known as ‘differential’, ‘unit’ or ‘absolutely selective’. Conversely, if the zone of protection is not unambiguously defined by the CTs, i.e. the limit of the zone varies with the fault current, the zone is said to be ‘non-unit’, ‘unrestricted’ or ‘relatively selective’. There is a certain degree of uncertainty about the location of the boundary of an open zone of protection. Generally, the nonpilot protection of transmission lines employs open zones of protection.

---



---

### Example 1.3

Consider the fault at  $F_1$  in Figure 1.9. This fault lies in a closed zone, and will cause circuit breakers  $B_1$  and  $B_2$  to trip. The fault at  $F_2$ , being inside the overlap between the zones of protection of the transmission line and the bus, will cause circuit breakers  $B_1$ ,  $B_2$ ,  $B_3$  and  $B_4$  to trip, although opening  $B_3$  and  $B_4$  is unnecessary. Both of these zones of protection are closed zones.

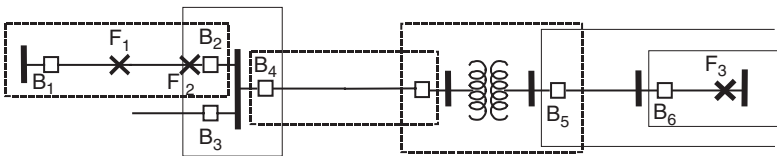

**Figure 1.9** Closed and open zones of protection

Now consider the fault at  $F_3$ . This fault lies in two open zones. The fault should cause circuit breaker  $B_6$  to trip.  $B_5$  is the backup breaker for this fault, and will trip if for some reason  $B_6$  fails to clear the fault.

---



---

#### 1.4.3 Relay speed

It is, of course, desirable to remove a fault from the power system as quickly as possible. However, the relay must make its decision based upon voltage and current waveforms which are severely

distorted due to transient phenomena which must follow the occurrence of a fault. The relay must separate the meaningful and significant information contained in these waveforms upon which a secure relaying decision must be based. These considerations demand that the relay take a certain amount time to arrive at a decision with the necessary degree of certainty. The relationship between the relay response time and its degree of certainty is an inverse one,<sup>2</sup> and this inverse-time operating characteristic of relays is one of the most basic properties of all protection systems.

Although the operating time of relays often varies between wide limits, relays are generally classified by their speed of operation as follows.<sup>3</sup>

1. **Instantaneous.** These relays operate as soon as a secure decision is made. No intentional time delay is introduced to slow down the relay response.<sup>†</sup>
2. **Time delay.** An intentional time delay is inserted between the relay decision time and the initiation of the trip action.<sup>‡</sup>
3. **High speed.** A relay that operates in less than a specified time. The specified time in present practice is 50 milliseconds (3 cycles on a 60 Hz system).
4. **Ultra high speed.** This term is not included in the Relay Standards but is commonly considered to be operation in 4 milliseconds or less.

#### 1.4.4 Primary and backup protection<sup>4,5</sup>

A protection system may fail to operate and, as a result, fail to clear a fault. It is thus essential that provision be made to clear the fault by some alternative protection system or systems. These alternative protection system(s) are referred to as duplicate, backup or breaker-failure protection systems. The main protection system for a given zone of protection is called the primary protection system. It operates in the fastest time possible and removes the least amount of equipment from service. On EHV systems it is common to use duplicate primary protection systems in case an element in one primary protection chain may fail to operate. This duplication is therefore intended to cover the failure of the relays themselves. One may use relays from a different manufacturer, or relays based upon a different principle of operation, so that some inadequacy in the design of one of the primary relays is not repeated in the duplicate system. The operating times of the primary and the duplicate systems are the same.

It is not always practical to duplicate every element of the protection chain – on high-voltage and EHV systems the transducers or the circuit breakers are very expensive, and the cost of duplicate equipment may not be justified. On lower voltage systems, even the relays themselves may not be duplicated. In such situations, only backup relaying is used. Backup relays are generally slower than the primary relays and remove more system elements than may be necessary to clear a fault. Backup relaying may be installed locally, i.e. in the same substation as the primary protection, or remotely. Remote backup relays are completely independent of the relays, transducers, batteries and circuit breakers of the protection system they are backing up. There are no common failures that can affect both sets of relays. However, complex system configurations may significantly affect the ability of remote backup relays to ‘see’ all the faults for which backup is desired. In addition, remote backup relays may remove more loads in the system than can be allowed. Local backup relaying does not suffer from these deficiencies, but it does use common elements such as the

<sup>†</sup> There is no implication relative to the speed of operation of an instantaneous relay. It is a characteristic of its design. A plunger-type overcurrent relay will operate in 1–3 cycles depending on the operating current relative to its pickup setting. A 125 V DC hinged auxiliary relay, operating on a 125 V DC circuit, will operate in 3–6 cycles, whereas a 48 V DC tripping relay operating on the same circuit will operate in 1 cycle. All are classified as instantaneous.

<sup>‡</sup> The inserted time delay can be achieved by an R–C circuit, an induction disc, a dashpot or other electrical or mechanical means. A short-time induction disc relay used for bus protection will operate in 3–5 cycles, a long-time induction disc relay used for motor protection will operate in several seconds and bellows or geared timing relays used in control circuits can operate in minutes.

transducers, batteries and circuit breakers, and can thus fail to operate for the same reasons as the primary protection.

Breaker failure relays are a subset of local backup relaying that is provided specifically to cover a failure of the circuit breaker. This can be accomplished in a variety of ways. The most common, and simplest, breaker failure relay system consists of a separate timer that is energized whenever the breaker trip coil is energized and is de-energized when the fault current through the breaker disappears. If the fault current persists for longer than the timer setting, a trip signal is given to all local and remote breakers that are required to clear the fault. Occasionally a separate set of relays is installed to provide this breaker failure protection, in which case it uses independent transducers, and batteries. (Also see Chapter 12 (Section 12.4).)

These ideas are illustrated by the following example, and will be further examined when specific relaying systems are considered in detail later.

### Example 1.4

Consider the fault at location F in Figure 1.10. It is inside the zone of protection of transmission line AB. Primary relays  $R_1$  and  $R_5$  will clear this fault by acting through breakers  $B_1$  and  $B_5$ . At station B, a duplicate primary relay  $R_2$  may be installed to trip the breaker  $B_1$  to cover the possibility that the relay  $R_1$  may fail to trip.  $R_2$  will operate in the same time as  $R_1$  and may use the same or different elements of the protection chain. For instance, on EHV lines it is usual to provide separate CTs, but use the same potential device with separate windings. The circuit breakers are not duplicated but the battery may be. On lower voltage circuits it is not uncommon to share all of the transducers and DC circuits. The local backup relay  $R_3$  is designed to operate at a slower speed than  $R_1$  and  $R_2$ ; it is probably set to see more of the system. It will first attempt to trip breaker  $B_1$  and then its breaker failure relay will trip breakers  $B_5$ ,  $B_6$ ,  $B_7$  and  $B_8$ . This is local backup relaying, often known as breaker-failure protection, for circuit breaker  $B_1$ . Relays  $R_9$ ,  $R_{10}$  and  $R_4$  constitute the remote backup protection for the primary protection  $R_1$ . No elements of the protection system associated with  $R_1$  are shared by these protection systems, and hence no common modes of failure between  $R_1$  and  $R_4$ ,  $R_9$  and  $R_{10}$  are possible. These remote backup protections will be slower than  $R_1$ ,  $R_2$  or  $R_3$ ; and also remove additional elements of the power system – namely lines BC, BD and BE – from service, which would also de-energize any loads connected to these lines.

A similar set of backup relays is used for the system behind station A.

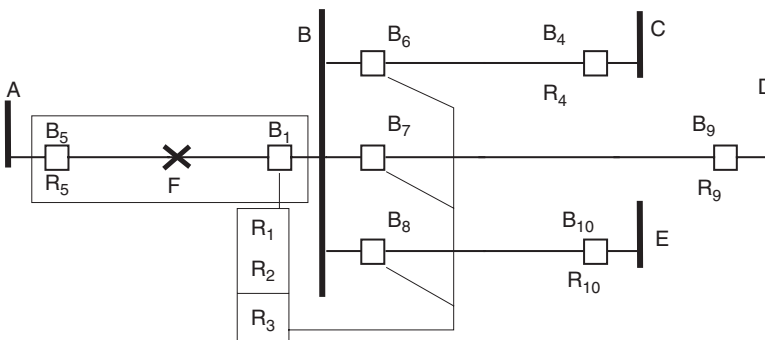

**Figure 1.10** Duplicate primary, local backup and remote backup protection

#### 1.4.5 Single- and three-phase tripping and reclosing

The prevailing practice in the USA is to trip all three phases of the faulted power system element for all types of fault. In several European and Asian countries, it is a common practice to trip only the faulted phase for a phase-to-ground fault, and to trip all three phases for all multiphase faults on transmission lines. These differences in the tripping practice are the result of several fundamental differences in the design and operation of power systems, as discussed in section 1.6.

As a large proportion of faults on a power system are of a temporary nature, the power system can be returned to its prefault state if the tripped circuit breakers are reclosed as soon as possible. Reclosing can be manual. That is, it is initiated by an operator working from the switching device itself, from a control panel in the substation control house or from a remote system control center through a supervisory control and data acquisition (SCADA) system. Clearly, manual reclosing is too slow for the purpose of restoring the power system to its prefault state when the system is in danger of becoming unstable. Automatic reclosing of circuit breakers is initiated by dedicated relays for each switching device, or it may be controlled from a substation or central reclosing computer. All reclosing operations should be supervised (i.e. controlled) by appropriate interlocks to prevent an unsafe, damaging or undesirable reclosing operation. Some of the common interlocks for reclosing are the following.

1. **Voltage check.** Used when good operating practice demands that a certain piece of equipment be energized from a specific side. For example, it may be desirable to always energize a transformer from its high-voltage side. Thus if a reclosing operation is likely to energize that transformer, it would be well to check that the circuit breaker on the low-voltage side is closed only if the transformer is already energized.
2. **Synchronizing check.** This check may be used when the reclosing operation is likely to energize a piece of equipment from both sides. In such a case, it may be desirable to check that the two sources which would be connected by the reclosing breaker are in synchronism and approximately in phase with each other. If the two systems are already in synchronism, it would be sufficient to check that the phase angle difference between the two sources is within certain specified limits. If the two systems are likely to be unsynchronized, and the closing of the circuit breaker is going to synchronize the two systems, it is necessary to monitor the phasors of the voltages on the two sides of the reclosing circuit breaker and close the breaker as the phasors approach each other.
3. **Equipment check.** This check is to ensure that some piece of equipment is not energized inadvertently.

These interlocks can be used either in the manual or in the automatic mode. It is the practice of some utilities, however, not to inhibit the manual reclose operation of circuit breakers, on the assumption that the operator will make the necessary checks before reclosing the circuit breaker. In extreme situations, sometimes the only way to restore a power system is through operator intervention, and automatic interlocks may prevent or delay the restoration operation. On the other hand, if left to the operator during manual operation, there is the possibility that the operator may not make the necessary checks before reclosing.

Automatic reclosing can be high speed, or it may be delayed. The term high speed generally implies reclosing in times shorter than a second. Many utilities may initiate high-speed reclosing for some types of fault (such as ground faults), and not for others. Delayed reclosing usually operates in several seconds or even in minutes. The timing for the delayed reclosing is determined by specific conditions for which the delay is introduced.

## 1.5 Elements of a protection system

Although, in common usage, a protection system may mean only the relays, the actual protection system consists of many other subsystems which contribute to the detection and removal of faults. As shown in Figure 1.11, the major subsystems of the protection system are the transducers, relays, battery and circuit breakers. The transducers, i.e. the current and voltage transformers, constitute a major component of the protection system, and are considered in detail in Chapter 3. Relays are the logic elements which initiate the tripping and closing operations, and we will, of course, discuss relays and their performance in the rest of this book.

### 1.5.1 Battery and DC supply

Since the primary function of a protection system is to remove a fault, the ability to trip a circuit breaker through a relay must not be compromised during a fault, when the AC voltage available in the substation may not be of sufficient magnitude. For example, a close-in three-phase fault can result in zero AC voltage at the substation AC outlets. Tripping power, as well as the power required by the relays, cannot therefore be obtained from the AC system, and is usually provided by the station battery.

The battery is permanently connected through a charger to the station AC service, and normally, during steady-state conditions, it floats on the charger. The charger is of a sufficient volt–ampere capacity to provide all steady-state loads powered by the battery. Usually, the battery is also rated to maintain adequate DC power for 8–12 hours following a station blackout. Although the battery is probably the most reliable piece of equipment in a station, in EHV stations it is not uncommon to have duplicate batteries, each connected to its own charger and complement of relays. Electromechanical relays are known to produce severe transients on the battery leads during operation, which may cause mis-operation of other sensitive relays in the substation, or may even damage them. It is therefore common practice, insofar as practical, to separate electromechanical and solid-state equipment by connecting them to different batteries.

### 1.5.2 Circuit breakers

It would take too much space to describe various circuit breaker designs and their operating principles here. Indeed, several excellent references do just that.<sup>6,7</sup> Instead, we will describe a few salient features about circuit breakers, which are particularly significant from the point of view of relaying.

Knowledge of circuit breaker operation and performance is essential to an understanding of protective relaying. It is the coordinated action of both that results in successful fault clearing. The

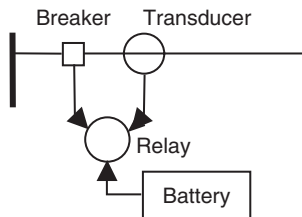
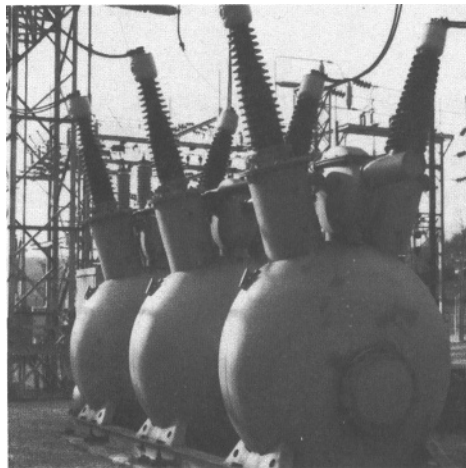

**Figure 1.11** Elements of a protection system

circuit breaker isolates the fault by interrupting the current at or near a current zero. At the present time, an EHV circuit breaker can interrupt fault currents of the order of  $10^5$  A at system voltages up to 800 kV. It can do this as quickly as the first current zero after the initiation of a fault, although it more often interrupts at the second or third current zero. As the circuit breaker contacts move to interrupt the fault current, there is a race between the establishment of the dielectric strength of the interrupting medium and the rate at which the recovery voltage reappears across the breaker contacts. If the recovery voltage wins the race, the arc re-ignites, and the breaker must wait for the next current zero when the contacts are farther apart.

Circuit breakers of several designs can be found in a power system. One of the first designs, and one that is still in common use, incorporates a tank of oil in which the breaker contacts and operating mechanism are immersed. The oil serves as the insulation between the tank, which is at the ground potential, and the main contacts, which are at line potential. The oil also acts as the cooling medium to quench the arc when the contacts open to interrupt load or fault current. An oil circuit breaker rated for 138 kV service is shown in Figure 1.12.

As transmission system voltages increased, it was not practical to build a tank large enough to provide the dielectric strength required in the interrupting chamber. In addition, better insulating materials, better arc quenching systems and faster operating requirements resulted in a variety of circuit breaker characteristics: interrupting medium of oil, gas, air or vacuum; insulating medium of oil, air, gas or solid dielectric; and operating mechanisms using impulse coil, solenoid, spring–motor–pneumatic or hydraulic. This broad selection of circuit breaker types and accompanying selection of ratings offers a high degree of flexibility. Each user has unique requirements and no design can be identified as the best or preferred design. One of the most important parameters to be considered in the specification of a circuit breaker is the interrupting medium. Oil does not require energy input from the operating mechanism to extinguish the arc. It gets that energy directly from the arc itself. Sulfur hexafluoride ( $\text{SF}_6$ ), however, does require additional energy and must operate at high pressure or develop a blast of gas or air during the interruption phase. When environmental factors are considered, however, oil circuit breakers produce high noise and ground shock during interruption, and for this reason may be rejected. They are also potential fire hazards, or water table pollutants.  $\text{SF}_6$  circuit breakers have essentially no emission, although the noise accompanying their operation may require special shielding and housing. And



**Figure 1.12** A 138 kV oil circuit breaker. (Courtesy of Appalachian Power Company)

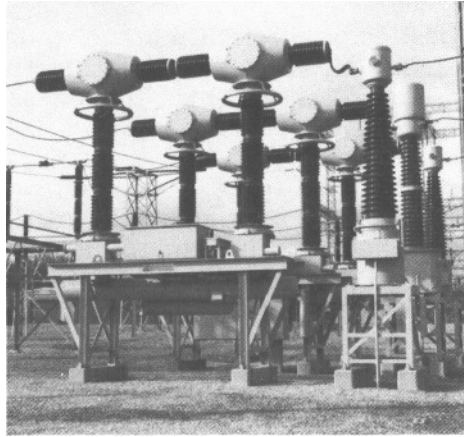

**Figure 1.13** A 345 kV SF<sub>6</sub> circuit breaker. (Courtesy of Appalachian Power Company)

as with all engineering decisions, the cost of the circuit breaker must be an important consideration. At present, oil-filled circuit breakers are the least expensive, and may be preferred if they are technically feasible, but this may change in the future. A typical SF<sub>6</sub> circuit breaker is shown in Figure 1.13.

An important design change in circuit breakers with a significant impact on protection systems was the introduction of the ‘live-tank’ design.<sup>8</sup> By placing the contact enclosure at the same potential as the contacts themselves, the need for the insulation between the two was eliminated. However the earlier ‘dead-tank’ (Figure 1.12) designs incorporated CTs in the bushing pocket of the tank, thereby providing CTs on both sides of the contacts. This arrangement provided a very nice mechanism for providing overlapping zones of protection on the two sides of the circuit breakers. In the live-tank design, since the entire equipment is at line potential, it is not possible to incorporate CTs which have their secondary windings essentially at the ground potential. It then becomes necessary to design the CTs with their own insulating system, as separate free-standing devices, a design which is quite expensive. With free-standing CTs, it is no longer economical to provide CTs on both

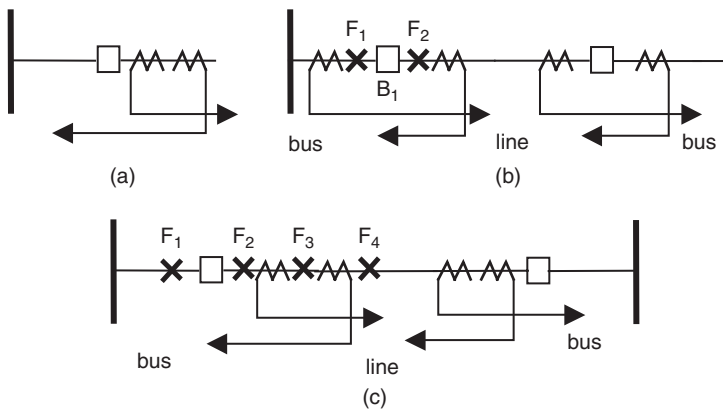

**Figure 1.14** Zone overlap with different types of CTs and circuit breakers

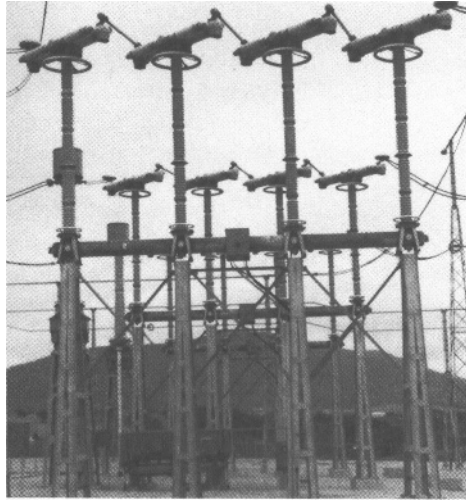

**Figure 1.15** Live-tank air-blast circuit breaker and a current transformer for 800 kV. (Courtesy of Appalachian Power Company)

sides of a circuit breaker, and one must make do with only one CT on one side of the breaker. Of course, a free-standing CT has multiple secondaries, and protection zone overlap is achieved by using secondary windings on opposite sides of the zones of protection. This is illustrated in Figure 1.14(a). A live-tank air-blast circuit breaker and a free-standing CT rated at 800 kV are shown in Figure 1.15. The location of the primary winding and the protective assignments of the secondary winding of the CTs have a very significant implication for the protection being provided. This is illustrated in the following example.

### Example 1.5

Consider the dead-tank circuit breaker shown in Figure 1.14(b). The bushing CTs are on either side of the breaker and the secondaries are connected to the bus and line protection so that they overlap at the breaker. For a fault at  $F_1$  both protective systems will operate. The bus differential relays will trip  $B_1$  and all other breakers on the bus. This will clear the fault. The line protection will similarly trip breaker  $B_1$ ; and the corresponding relays at the remote station will also trip their associated breakers. This is unnecessary, but unavoidable. If there are tapped loads on the line, they will be de-energized until the breakers reclose. For a fault at  $F_2$ , again both protective systems will operate. For this fault, tripping the other bus breakers is not necessary to clear the fault, but tripping the two ends of the line is necessary.

Now consider the live-tank design shown in Figure 1.14(c). For a fault at  $F_1$ , only the bus protection sees the fault and correctly trips  $B_1$  and all the other bus breakers to clear the fault. For a fault at  $F_2$ , however, tripping the bus breakers does not clear the fault, since it is still energized from the remote end, and the line relays do not operate. This is a blind spot in this configuration. Column protection will cover this area. For a fault at  $F_3$  and  $F_4$ , the line relays will operate and the fault will be cleared from both ends. The fault at  $F_3$  again results in unnecessary tripping of the bus breakers.

## 1.6 International practices

Although the fundamental protective and relay operating concepts are similar throughout the world, there are very significant differences in their implementation. These differences arise through different traditions, operating philosophies, experiences and national standards. Electric power utilities in many countries are organs of the national government. In such cases, the specific relaying schemes employed by these utilities may reflect the national interest. For example, their preference may be for relays manufactured inside their respective countries. In some developing countries, the choice of relays may be influenced by the availability of low-cost hard-currency loans, or a transfer-of-technology agreement with the prospective vendor of the protective equipment. The evolutionary stage of the power system itself may have an influence on the protection philosophy. Thus more mature power systems may opt for a more dependable protection system at the expense of some degradation of its (protection system's) security. A developing power network has fewer alternative paths for power transfer between the load and generation, and a highly secure protection system may be the desired objective. Long transmission lines are quite common in countries with large areas, e.g. the USA or Russia. Many European and Asian countries have relatively short transmission lines, and, since the protection practice for long lines is significantly different from that for short lines, this may be reflected in the established relaying philosophy.

As mentioned in section 1.4, reclosing practices also vary considerably among different countries. When one phase of a three-phase system is opened in response to a single phase fault, the voltage and current in the two healthy phases tend to maintain the fault arc after the faulted phase is de-energized. Depending on the length of the line, system operating voltage and load, compensating shunt reactors may be necessary to extinguish this 'secondary' arc.<sup>9</sup> Where the transmission lines are short, such secondary arcs are not a problem, and no compensating reactors are needed. Thus in countries with short transmission lines, single-phase tripping and reclosing may be a sound and viable operating strategy. In contrast, when transmission lines are long, the added cost of compensation may dictate that three-phase tripping and reclosing be used for all faults. The loss of synchronizing power flow created by three-phase tripping is partially mitigated by the use of high-speed reclosing. Also, use is made of high-speed relaying (three cycles or less) to reduce the impact of three-phase tripping and reclosing. Of course, there are exceptional situations which may dictate a practice that is out of the ordinary in a given country. Thus, in the USA, where high-speed tripping with three-phase tripping and reclosing is the general trend, exception may be made when a single transmission line is used to connect a remote generator to the power system. Three-phase tripping of such a line for a ground fault may cause the loss of the generator for too many faults, and single-phase tripping and reclosing may be the desirable alternative.

An important factor in the application of specific relay schemes is associated with the configuration of the lines and substations. Multiple circuit towers as found throughout Europe have different fault histories than single circuit lines, and therefore have different protection system needs. The same is true for double-bus, transfer bus or other breaker bypassing arrangements. In the USA, EHV stations are almost exclusively breaker-and-a-half or ring bus configurations. This provision to do maintenance work on a breaker significantly affects the corresponding relaying schemes. The philosophy of installing several complete relay systems also affects the testing capabilities of all relays. In the USA, it is not the common practice to remove more than one phase or zone relay at a time for calibration or maintenance. In other countries this may not be considered to be as important, and the testing facilities built in the relays may not be as selective.

The use of turnkey contracts to design and install complete substations also differs considerably between countries, being more prevalent in many European, South American and certain Asian countries than in North America. This practice leads to a manufacturer or consulting engineering concern taking total project responsibility, as opposed to the North American practice where the utilities themselves serve as the general contractor. In the latter case, the effect is to reduce the variety of protection schemes and relay types in use.

## 1.7 Summary

In this chapter, we have examined some of the fundamentals of protective relaying philosophy. The concept of reliability and its two components, dependability and security, have been introduced. Selectivity has been illustrated by closed and open zones of protection and local versus remote backup. The speed of relay operation has been defined. Three-phase tripping, the prevailing practice in the USA, has been compared to the more prevalent European practice of single-phase tripping. We have discussed various reclosing and interlocking practices, and the underlying reasons for a given choice. We have also given a brief account of various types of circuit breaker, and their impact on the protection system design.

## Problems

- 1.1 Write a computer program to calculate the three-phase fault current for a fault at F in Figure 1.16, with the network normal, and with one line at a time removed from service. The positive sequence impedance data are given in the accompanying table. Use the commonly made assumption that all pre-fault resistance values are  $(1.0 + j0.0)$  pu, and neglect all resistance values. Calculate the contribution to the fault flowing through the circuit breaker  $B_1$ , and the voltage at that bus. For each calculated case, consider the two possibilities: circuit breaker  $B_2$  closed or open. The latter is known as the 'stub-end' fault.

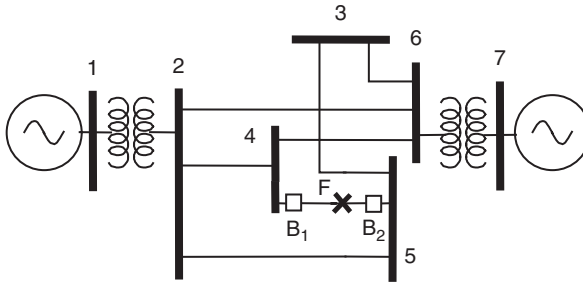

Figure 1.16 Problem 1.1

System data for Figure 1.16

From	To	Positive sequence impedance
1	2	$0.0 + j0.1$
2	6	$0.05 + j0.15$
2	5	$0.04 + j0.2$
2	4	$0.01 + j0.1$
3	5	$0.015 + j0.15$
3	6	$0.01 + j0.19$
4	5	$0.01 + j0.19$
4	6	$0.03 + j0.1$
6	7	$0.0 + j0.08$

- 1.2 Using the usual assumptions about the positive and negative sequence impedances of the network elements, what are the currents at breaker  $B_1$  for  $b-c$  fault for each of the faults in Problem 1.1? What is the voltage between phases  $b$  and  $c$  for each case?
- 1.3 For the radial power system shown in Figure 1.17, calculate the line-to-ground fault current flowing in each of the circuit breakers for faults at each of the buses. The system data are given in the accompanying table. Also determine the corresponding faulted phase voltage, assuming that the generator is ideal, with a terminal voltage of 1.0 pu.

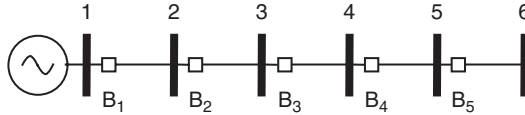

Figure 1.17 Problem 1.3

System data for Figure 1.17

From	To	Positive sequence impedance	Zero sequence impedance
1	2	$0.01 + j0.05$	$0.02 + j0.13$
2	3	$0.003 + j0.04$	$0.01 + j0.16$
3	4	$0.008 + j0.04$	$0.04 + j0.15$
4	5	$0.01 + j0.05$	$0.03 + j0.15$
5	6	$0.003 + j0.02$	$0.01 + j0.06$

- 1.4 In a single loop distribution system shown in Figure 1.18, determine the fault currents flowing in circuit breakers  $B_1$ ,  $B_2$  and  $B_3$  for a  $b-c$  fault at F. What are the corresponding phase-to-phase voltages at those locations? Consider the generator to be of infinite short-circuit capacity, and with a voltage of 1.0 pu. Consider two alternatives: (a) both transformers  $T_1$  and  $T_2$  in service and (b) one of the two transformers out of service. The system data are given in the accompanying table.

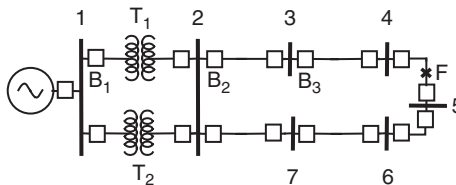

Figure 1.18 Problem 1.4

System data for Figure 1.18

From	To	Positive sequence impedance
1	2	$0.0 + j0.01(T_1)$ $0.0 + j0.01(T_2)$
2	3	$0.0 + j0.08$
3	4	$0.02 + j0.05$
4	5	$0.01 + j0.03$
5	6	$0.0 + j0.06$
6	7	$0.01 + j0.09$
2	7	$0.01 + j0.09$

- 1.5 In the double-bus arrangement shown in Figure 1.19, circuit breaker B<sub>1</sub> must be taken out of service for repair. Starting with all equipment in service, make a list of operations required to take the circuit breaker out of service, and to return it to service. Repeat for all the bus arrangements shown in Figure 1.7. Remember that disconnect switches are generally not designed to break or make load current.

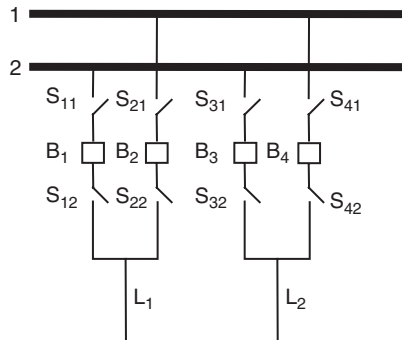

Figure 1.19 Problem 1.5

- 1.6 Consider the various bus arrangements shown in Figure 1.7. Assume that each of the device types, bus, disconnect switch, circuit breaker and transmission line, may develop a fault and is removed from service. Prepare a table listing (single) faults which would cause loss of load connected to the remote end of one of the transmission lines in each of those configurations. What conclusions can you draw from such a table?
- 1.7 For the system shown in Figure 1.20, the fault at F produces these differing responses at various times: (a) R<sub>1</sub> B<sub>1</sub> and R<sub>2</sub> B<sub>2</sub> operate; (b) R<sub>1</sub> B<sub>1</sub>, R<sub>2</sub>, R<sub>3</sub> B<sub>3</sub> and R<sub>4</sub> B<sub>4</sub> operate; (c) R<sub>1</sub> B<sub>1</sub>, R<sub>2</sub> B<sub>2</sub> and R<sub>5</sub> B<sub>5</sub> operate; (d) R<sub>1</sub> B<sub>1</sub>, R<sub>5</sub> B<sub>5</sub> and R<sub>6</sub> B<sub>6</sub> operate. Analyze each of these responses for fault F and discuss the possible sequence of events that may have led to these operations. Classify each response as being correct, incorrect, appropriate or

inappropriate. Note that ‘correct–incorrect’ classification refers to relay operation, whereas ‘appropriate–inappropriate’ classification refers to the desirability of that particular response from the point of view of the power system. Also determine whether there was a loss of dependability or a loss of security in each of these cases.

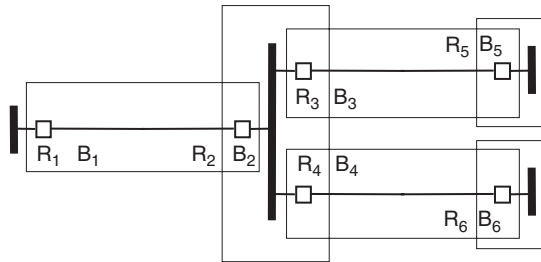

Figure 1.20 Problem 1.7

- 1.8 In the systems shown in Figure 1.21(a) and (b), it is desired to achieve overlap between the zones of protection for the bus and the transmission line. Show how this may be achieved through the connection of CTs to the appropriate protection systems.

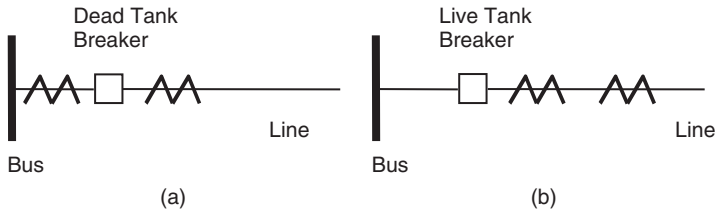

Figure 1.21 Problem 1.8

- 1.9 In the part of the network shown in Figure 1.22, the minimum and maximum operating times for each relay are 0.8 and 2.0 cycles (of the fundamental power system frequency), and each circuit breaker has minimum and maximum operating times of 2.0 and 5.0 cycles. Assume that a safety margin of 3.0 cycles between any primary protection and backup protection is desirable.  $P_2$  is the local backup for  $P_1$ , and  $P_3$  is the remote backup. Draw a timing diagram to indicate the various times at which the associated relays and breakers must operate to provide a secure (coordinated) backup coverage for fault F.



Figure 1.22 Problem 1.9

- 1.10** For the system shown in Figure 1.23, the following circuit breakers are known to operate: (a) B<sub>1</sub> and B<sub>2</sub>; (b) B<sub>3</sub>, B<sub>4</sub>, B<sub>1</sub>, B<sub>5</sub> and B<sub>7</sub>; (c) B<sub>7</sub> and B<sub>8</sub>; (d) B<sub>1</sub>, B<sub>3</sub>, B<sub>5</sub> and B<sub>7</sub>. Assuming that all primary protection has worked correctly, where is the fault located in each of these cases?

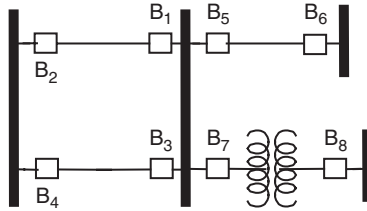

**Figure 1.23** Problem 1.10

## References

1. *IEEE Standard Dictionary of Electrical and Electronic Terms*, ANSI/IEEE 100.
2. Thorp, J.S., Phadke, A.G., Horowitz, S.H. and Beehler, J.E. (1979) Limits to impedance relaying. *IEEE Trans. PAS*, **98** (1), 246–60.
3. Systems used for supervisory control, data acquisition and automatic control, definition, specification, and analysis, ANSI/IEEE C37.1
4. Kennedy, L.F. and McConnell, A.J. (1957) An appraisal of remote and local backup relaying. *AIEE Trans.*, **76** (1), 735–41.
5. IEEE Committee (1970) Local backup relaying protection. *IEEE Trans. PAS*, **89**, 1061–8.
6. Lythall, R.T. (1953) *The J. & P. Switchgear Book*, Johnson & Phillips, London.
7. Willheim, R. and Waters, M. (1956) *Neutral Grounding in High-Voltage Transmission*, Elsevier.
8. Shores, R.B., Beatty, J.W. and Seeley, H.T. (1959) A line of 115 kV through 460 kV air blast breakers. *AIEE Trans. PAS*, **58**, 673–91.
9. Shperling, B.R., Fakheri, A.J., Shih, C. and Ware, B.J. (1981) Analysis of single phase switching field tests on the AEP 765 kV system. *IEEE Trans. PAS*, **100**, 1729–35.