

1

Drawing Tools and Materials

This chapter introduces the pencils and pens necessary for inscribing lines, the instruments available for guiding the eye and hand while drawing, and the surfaces suitable for receiving the drawn lines. While digital technology continues to further augment and enhance this traditional drawing toolkit, the kinesthetic act of drawing with a hand-held pencil or pen remains the most direct and versatile means of learning the language of architectural graphics.

COPYRIGHTED MATERIAL

Pencils are relatively inexpensive, quite versatile, and uniquely responsive to pressure while drawing.

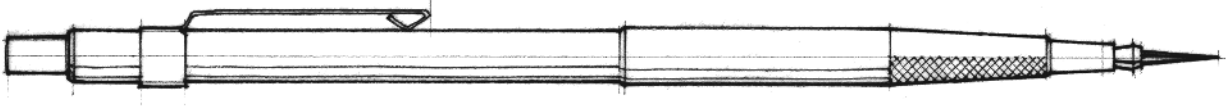

Lead Holders

- Lead holders employ standard 2 mm leads.
- The push-button action of a clutch mechanism allows the exposed length of the lead shaft to be adjusted or withdrawn when the pencil is not in use.
- The lead point, which is capable of a variety of line weights, must be kept well sharpened with a lead pointer.

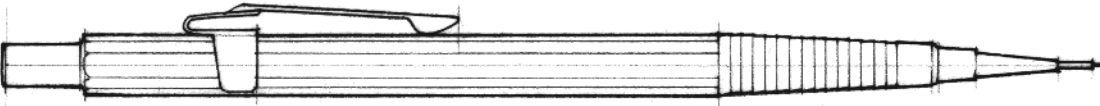

Mechanical Pencils

- Mechanical pencils utilize 0.3 mm, 0.5 mm, 0.7 mm, and 0.9 mm leads.
- A push-button mechanism advances the lead automatically through a metal sleeve. This sleeve should be long enough to clear the edges of drafting triangles and straightedges.
- The relatively thin leads of mechanical pencils do not require sharpening.
- 0.3 mm pencils yield very fine lines, but the thin leads are susceptible to breaking if applied with too much pressure.
- 0.5 mm pencils are the most practical for general drawing purposes.
- 0.7 mm and 0.9 mm pencils are useful for sketching and writing; avoid using these pencils to produce heavy line weights.

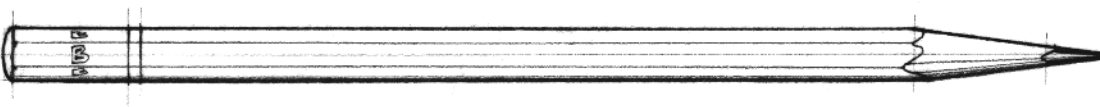
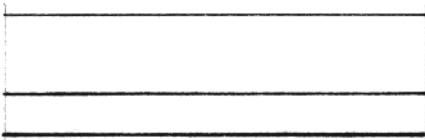

Wood-Encased Pencils

- Wooden drawing pencils are typically used for freehand drawing and sketching. If used for drafting, the wood must be shaved back to expose $\frac{3}{4}$ " of the lead shaft so that it can be sharpened with sandpaper or a lead pointer.

All three styles of pencils are capable of producing quality line drawings. As you try each type out, you will gradually develop a preference for the characteristic feel, weight, and balance of a particular instrument as you draw.

Graphite Leads

Grades of graphite lead for drawing on paper surfaces range from 9H (extremely hard) to 6B (extremely soft). Given equal hand pressure, harder leads produce lighter and thinner lines, whereas softer leads produce denser, wider lines.

Nonphoto Blue Leads

Nonphoto blue leads are used for construction lines because their shade of blue tend not to be detected by photocopiers. However, digital scanners can detect the light blue lines, which can be removed by image editing software.

Plastic Leads

Specially formulated plastic polymer leads are available for drawing on drafting film. Grades of plastic lead range from E0, N0, or P0 (soft) to E5, N5, or P5 (hard). The letters E, N, and P are manufacturers' designations; the numbers 0 through 5 refer to degrees of hardness.

Recommendations for Grades of Graphite Lead

4H

- This dense grade of lead is best suited for accurately marking and laying out light construction lines.
- The thin, light lines are difficult to read and reproduce and should therefore not be used for finish drawings.
- When applied with too much pressure, the dense lead can engrave paper and board surfaces, leaving grooves that are difficult to remove.

2H

- This medium-hard lead is also used for laying out drawings and is the densest grade of lead suitable for finish drawings.
- 2H lines do not erase easily if drawn with a heavy hand.

F and H

- These are general-purpose grades of lead suitable for layouts, finish drawings, and handlettering.

HB

- This relatively soft grade of lead is capable of dense linework and handlettering.
- HB lines erase and print well but tend to smear easily.
- Experience and good technique are required to control the quality of HB linework.

B

- This soft grade of lead is used for very dense linework and handlettering.

The texture and density of a drawing surface affect how hard or soft a pencil lead feels. The more tooth or roughness a surface has, the harder the lead you should use; the more dense a surface is, the softer a lead feels.

Technical Pens

Technical pens are capable of producing precise, consistent ink lines without the application of pressure. As with lead holders and mechanical pencils, technical pens from different manufacturers vary in form and operation. The traditional technical pen utilizes an ink-flow-regulating wire within a tubular point, the size of which determines the width of the ink line.

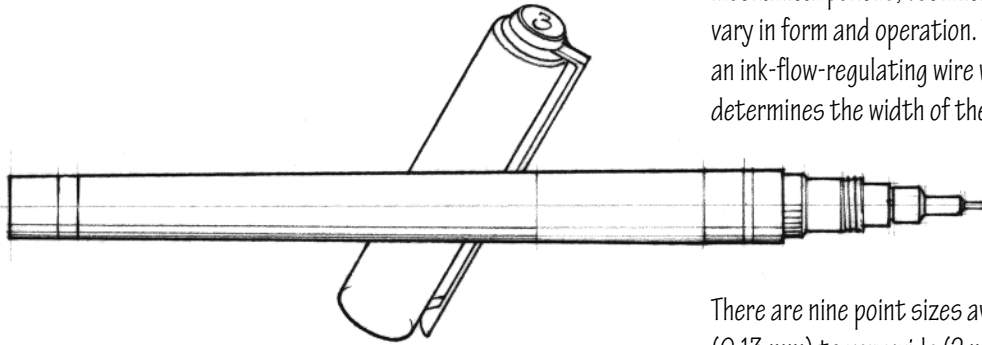

There are nine point sizes available, from extremely fine (0.13 mm) to very wide (2 mm). A starting pen set should include the four standard line widths—0.25 mm, 0.35 mm, 0.5 mm and 0.70 mm—specified by the International Organization for Standardization (ISO).

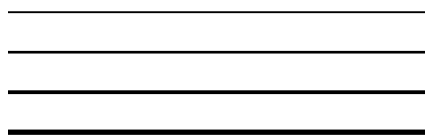

- 0.25 mm line width
- 0.35 mm line width
- 0.50 mm line width
- 0.70 mm line width

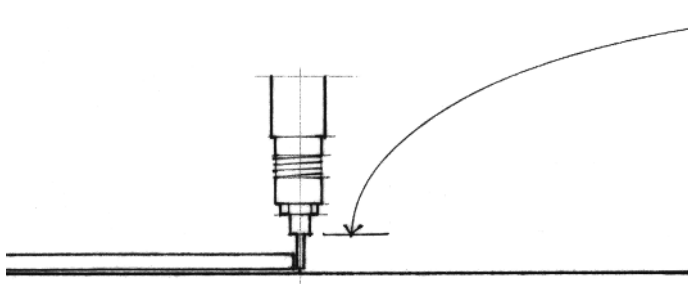

- The tubular point should be long enough to clear the thickness of drafting triangles and straightedges.
- Use waterproof, nonclogging, fast-drying black drawing ink.
- Keep points screwed in securely to prevent ink leaking.
- After each use, replace the pen cap firmly to prevent the ink from drying.
- When pens are not in use, store them horizontally.

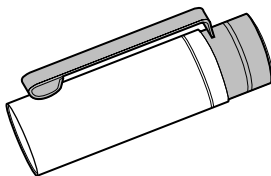
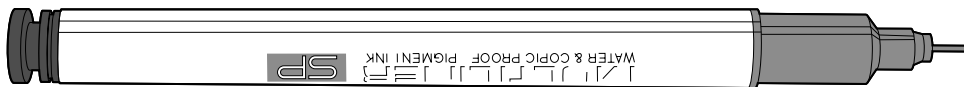

Since digital tools have reduced the need for manual drafting, a variety of less expensive, low-maintenance technical pens have been developed. Equipped with tubular tips and waterproof, pigment-based ink, these pens are suitable for writing, freehand drawing, as well as drafting with straightedges. They are available in point sizes that range from 0.03 mm to 1.0 mm. Some are refillable and have replaceable nibs.

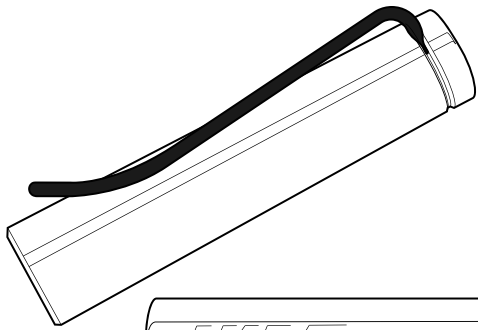

Fountain Pens

Fountain pens typically consist of a reservoir—either a disposable cartridge or an internal piston—containing a water-based ink that is fed to a metal nib by capillary action. While not suitable for drafting, fountain pens are ideal for writing and freehand sketching because they offer ease in drawing fluid, incisive, often expressive lines with little or no pressure.

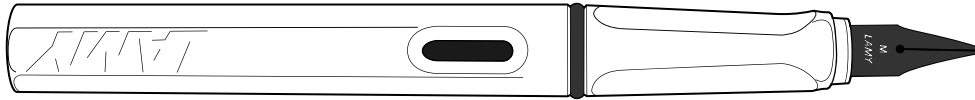

Fountain pen nibs come in extra-fine, fine, medium and broad sizes; flat tipped nibs are also available for italic and oblique strokes. Some nibs are flexible enough that they respond to individual stroke direction and pressure.

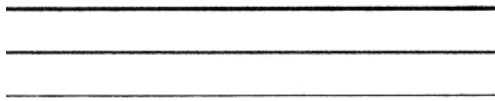

Other Drawing Pens

Gel pens use a thick, opaque ink consisting of pigment suspended in a water-based gel while rollerball pens use a water-based liquid ink. Both offer similar qualities to fountain pens—they are capable of a consistent ink flow and laying down lines with less pressure than that required by regular ballpoint pens.

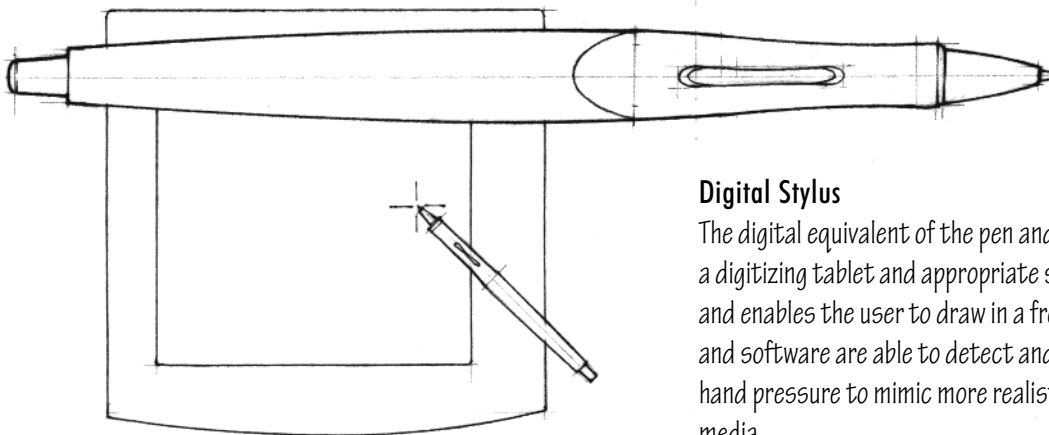

Digital Stylus

The digital equivalent of the pen and pencil is the stylus. Used with a digitizing tablet and appropriate software, it replaces the mouse and enables the user to draw in a freehand manner. Some models and software are able to detect and respond to the amount of hand pressure to mimic more realistically the effects of traditional media.

DRAWING GUIDES

T-Squares

T-squares are straightedges that have a short crosspiece at one end. This head slides along the edge of a drawing board as a guide in establishing and drawing straight parallel lines. T-squares are relatively low in cost and portable but require a straight and true edge against which their heads can slide.

- This end of a T-square is subject to wobbling.

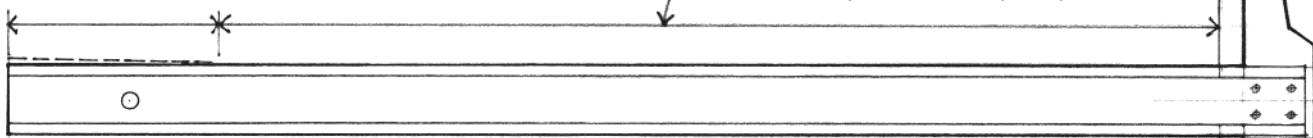

- T-squares are available in 18", 24", 30", 36", 42", and 48" lengths. 42" or 48" lengths are recommended.

- A metal angle secured to the drawing board can provide a true edge.

- T-squares with clear, acrylic straightedges should not be used for cutting. Metal T-squares are available for this purpose.

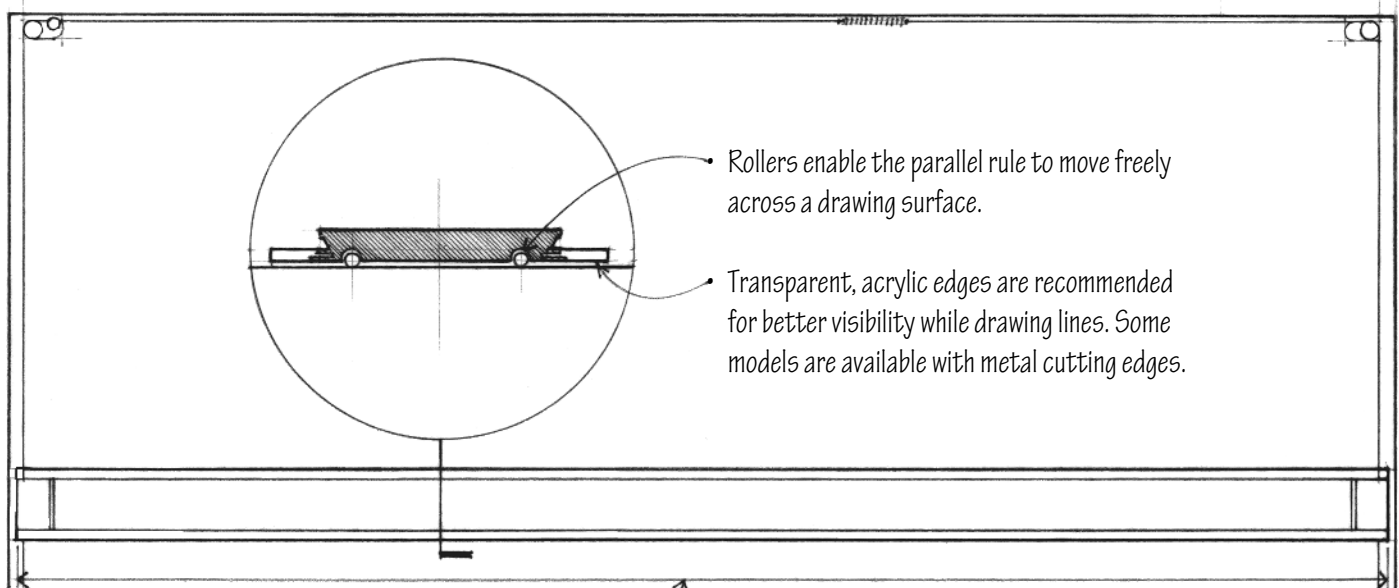

Parallel Rules

Parallel rules are equipped with a system of cables and pulleys that allows their straightedges to move across a drawing board only in a parallel manner. Parallel rules are more expensive and less portable than T-squares but enable one to draft with greater speed and accuracy.

- Parallel rules are available in 30", 36", 42", 48", 54", and 60" lengths. The 42" or 48" length is recommended.

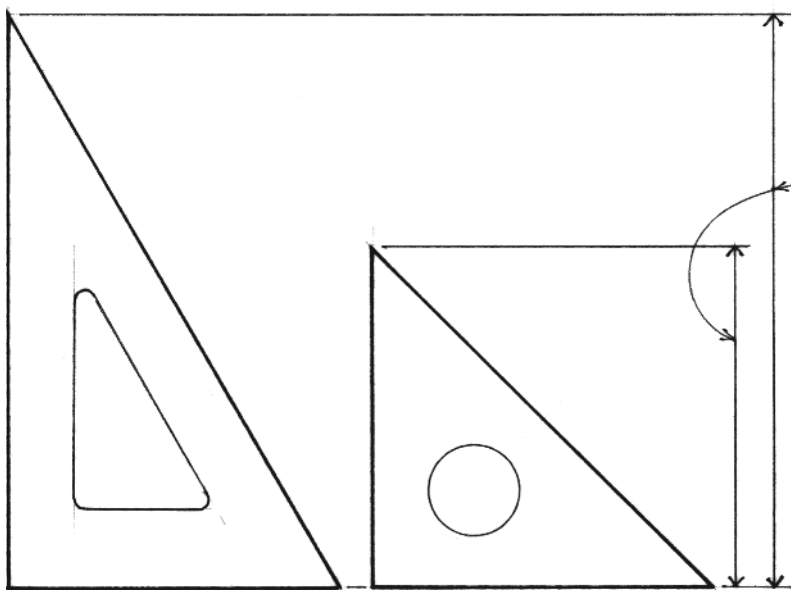

Triangles

Triangles are drafting aids used to guide the drawing of vertical lines and lines at specified angles. They have a right angle and either two 45° angles or one 30° and one 60° angle.

- 4" to 24" lengths are available.
- 8" to 10" lengths are recommended.
- Small triangles are useful for crosshatching small areas and as a guide in handlettering. See page 204.
- Larger triangles are useful in constructing perspectives.
- The $45^\circ-45^\circ$ and $30^\circ-60^\circ$ triangles can be used in combination to produce angular increments of 15° . See page 24.
- Triangles are made of clear, scratch-resistant, non-yellowing acrylic to allow a transparent, undistorted view through to the work below. Fluorescent orange acrylic triangles are also available for greater visibility on the drafting surface.
- Machined edges should be polished for precision and to facilitate drawing. Some triangles have raised edges for inking with technical pens.
- Inner edges may be beveled to serve as finger lifts.
- Keep triangles clean by washing with a mild soap and water.
- Triangles should not be used as a straightedge for cutting materials.

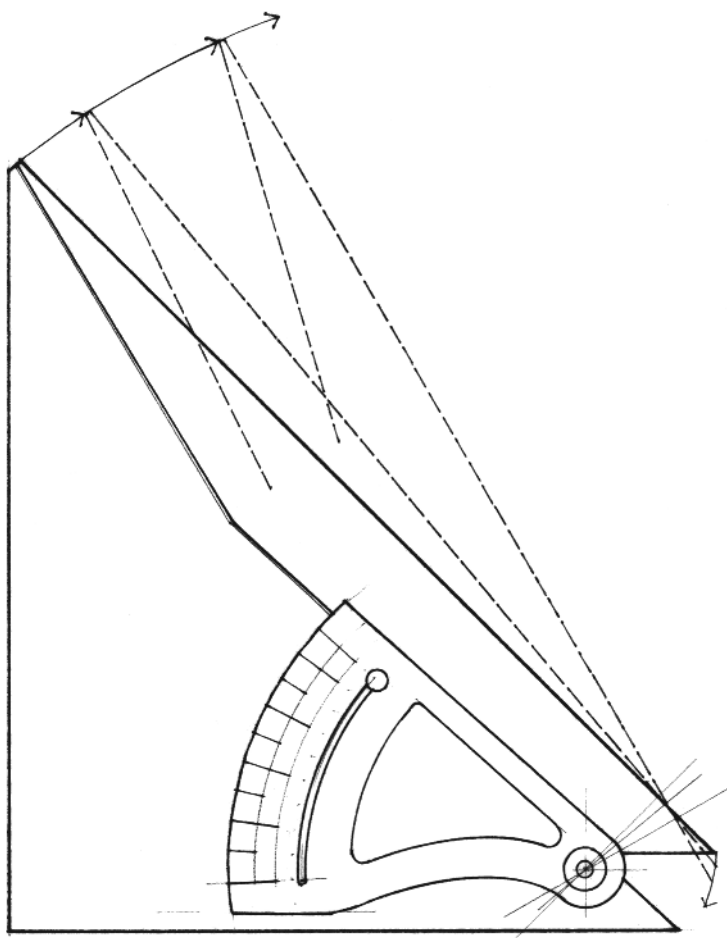

Adjustable Triangles

Adjustable triangles have a movable leg that is held in place with a thumbscrew and a scale for measuring angles. These instruments are useful for drawing such inclined lines as the slope of a stair or the pitch of a roof.

Compasses

The compass is essential for drawing large circles as well as circles of indeterminate radii.

- It is difficult to apply pressure when using a compass. Using too hard a grade of lead can therefore result in too light of a line. A softer grade of lead, sharpened to a chisel point, will usually produce the sharpest line without undue pressure. A chisel point dulls easily, however, and must be sharpened often.

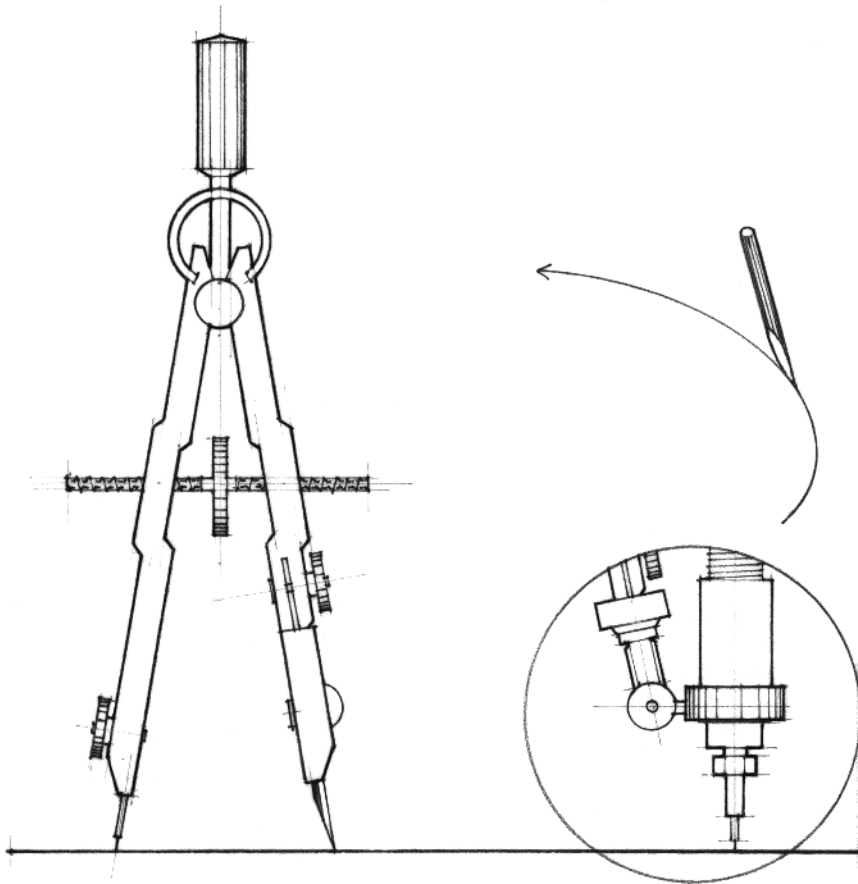

- An attachment allows technical pens to be used with a compass.

- Even larger circles can be drawn by appending an extension arm or using a beam compass.

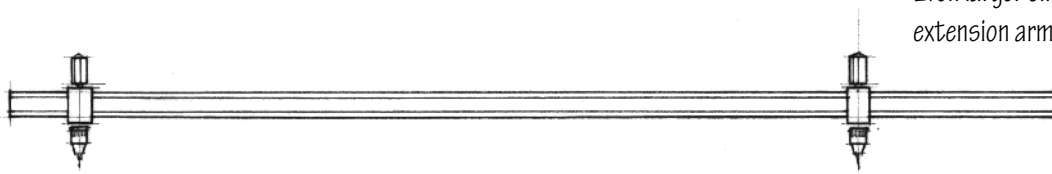

French Curves

- A variety of French curves are manufactured to guide the drawing of irregular curves.
- Adjustable curves are shaped by hand and held in position to draw a fair curve through a series of points.

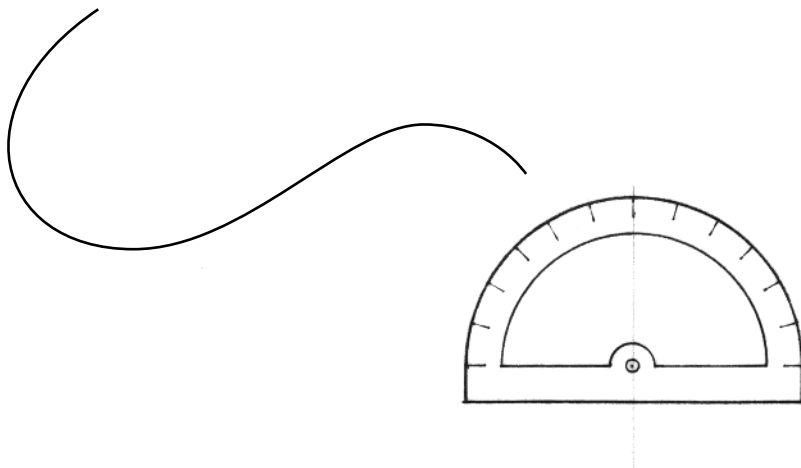

Protractors

- Protractors are semicircular instruments for measuring and plotting angles.

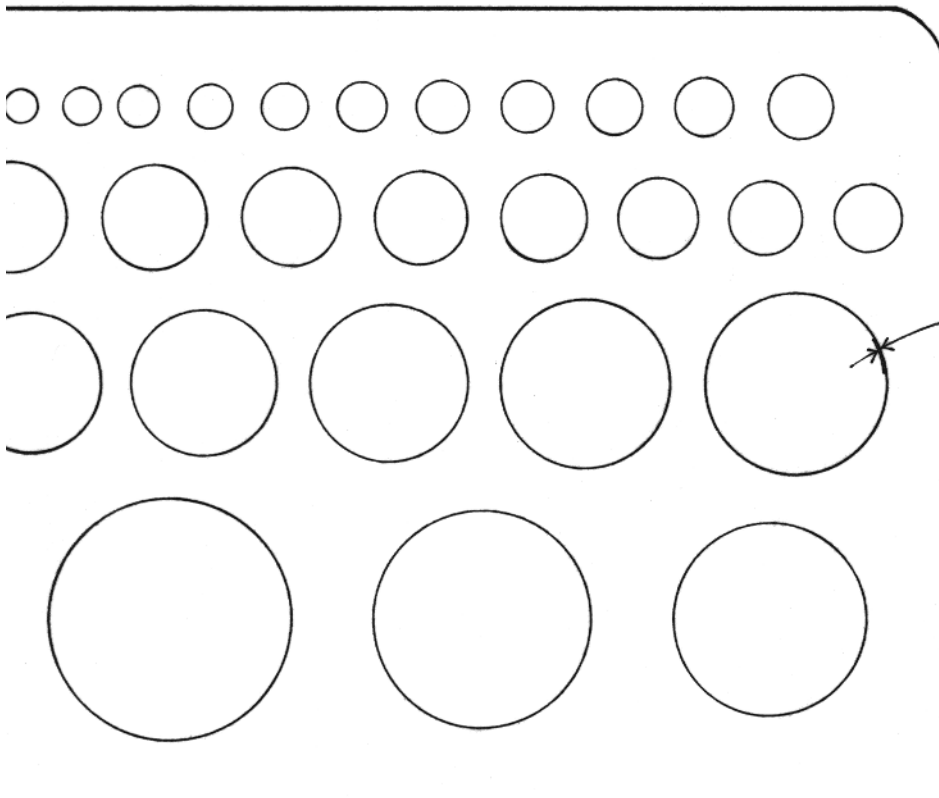

Templates

Templates have cutouts to guide the drawing of predetermined shapes.

- Circle templates provide a graduated series of circles commonly based on fractions and multiples of an inch. Metric sizes are also available.
- The actual size of a cutout differs from the drawn size due to the thickness of the lead shaft or pen tip.
- Some templates have dimples to raise them off of the drawing surface while inking.

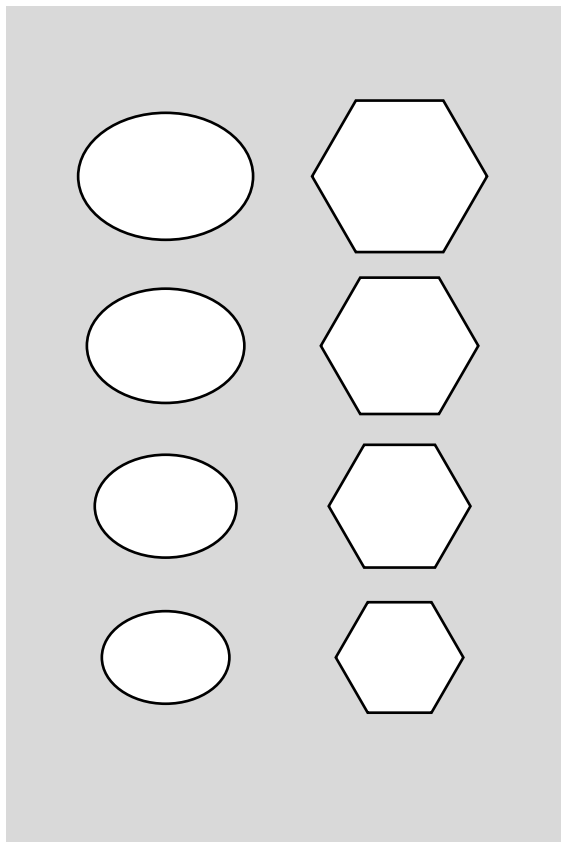
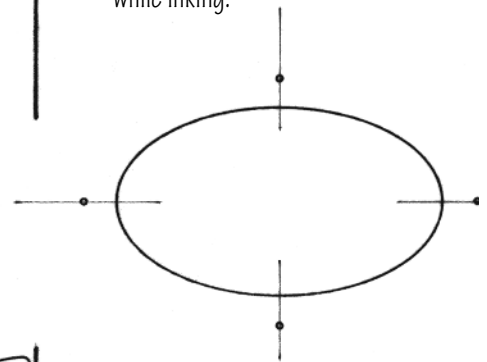

- Templates are available for drawing other geometric shapes, such as ellipses and polygons, as well as symbols for plumbing fixtures and furnishings at various scales.

Digital Drawing

Analogous to traditional hand drafting tools are the software capabilities of a 2D vector-based drawing program, which define lines—the quintessential element of architectural drawing—as mathematical vectors.

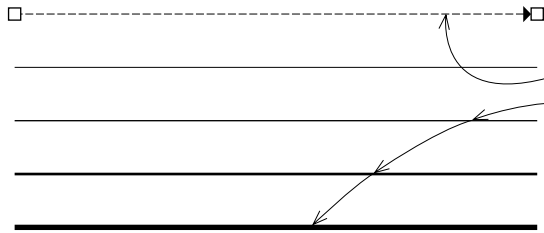

- A straight line segment can be created by clicking two endpoints.
- The weight of the stroke can be selected from a menu or by specifying its width in absolute terms (millimeters, fractions of an inch, or number of points, where 1 point = 1/72").

Digital Guides

Drawing programs typically have commands to constrain the movement of points and lines to a precise horizontal, vertical or diagonal direction. Grids and guidelines, along with snap-to commands, further aid the precise drawing of lines and shapes.

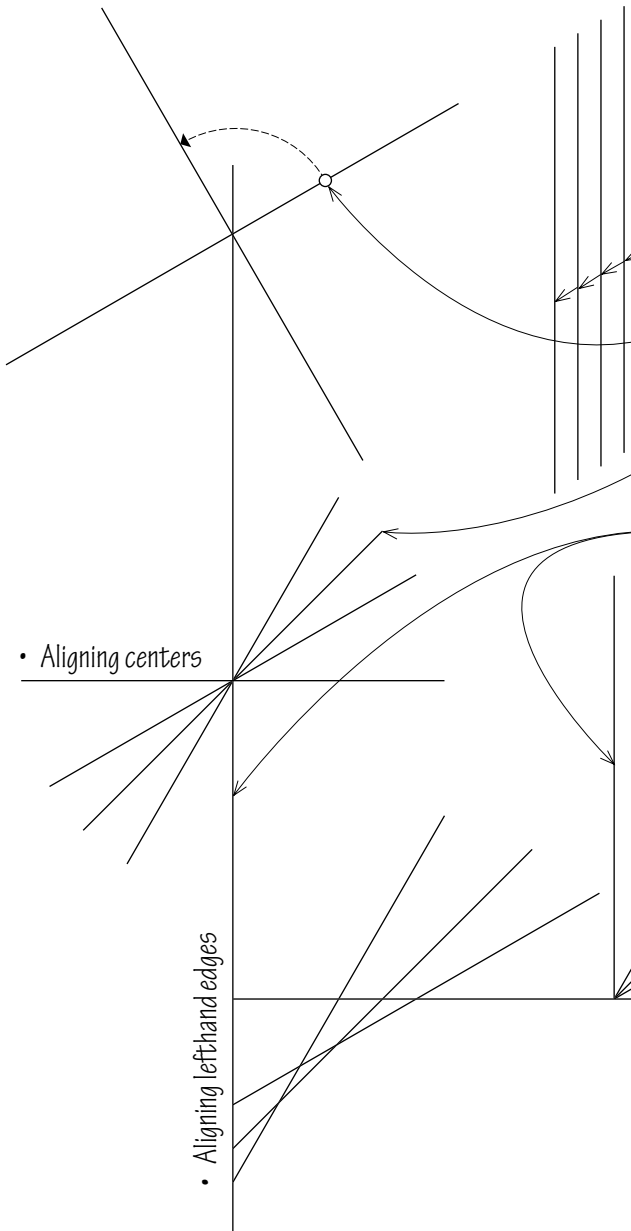

- Parallel lines can be drawn by moving a copy of an existing line a specified dimension and direction.
- Perpendicular lines can be drawn by rotating an existing line 90°.
- Smart guides can be set to draw lines at 30°, 45°, 60° or any specified angle.
- Sloping or inclined lines can be drawn by rotating an existing line the desired number of degrees.
- Guides can also be set to align or distribute the centers, lefthand or righthand edges, or tops or bottoms of line segments.

Digital Templates

2D drawing and computer-aided drafting (CAD) programs include digital templates of geometric shapes, furnishings, fixtures, as well as user-defined elements. Whether a template is physical or digital, its purpose remains the same—to save time when drawing repetitive elements.

Erasers

One of the advantages of drawing with a pencil is the ability to easily erase pencil marks. Always use the softest eraser compatible with the medium and the drawing surface. Avoid using abrasive ink erasers.

- Vinyl or PVC plastic erasers are nonabrasive and will not smear or mar the drawing surface.
- Some erasers are saturated with erasing fluid to erase ink lines from paper and drafting films.
- Liquid erasing fluid removes pencil and ink markings from drafting film.

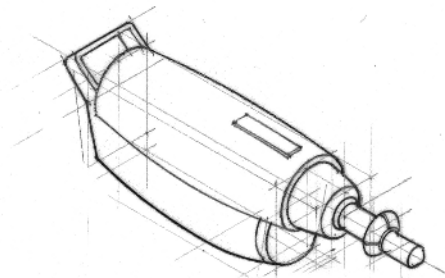

- Electric erasers are very convenient for erasing large areas and ink lines. Compact, battery-operated models are especially handy.

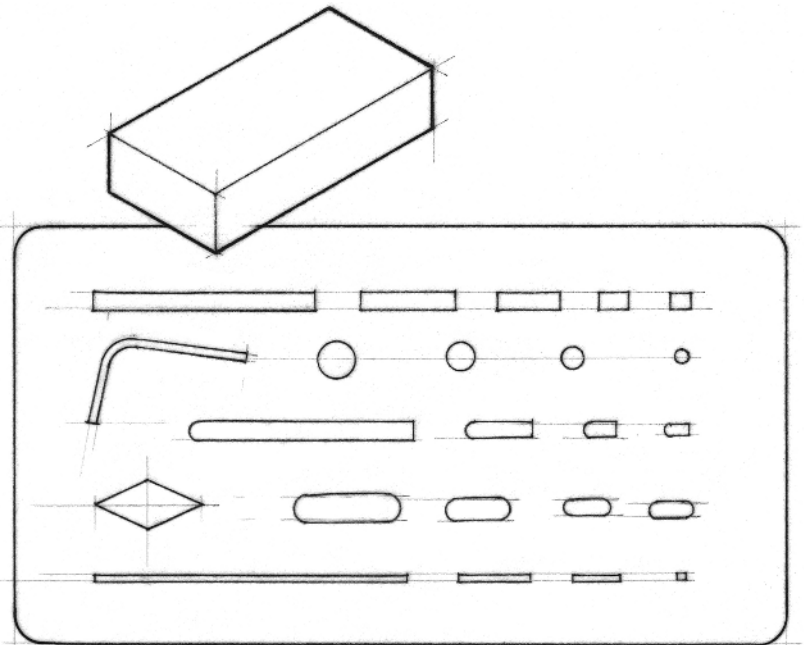

Erasing Shields

Erasing shields have cutouts of various shapes and sizes to confine the area of a drawing to be erased. These thin, stainless-steel shields are especially effective in protecting the drawing surface while using an electric eraser. Ones that have square-cut holes allow the erasure of precise areas of a drawing.

Other Aids

- Drafting brushes help keep the drawing surface clean of erasure fragments and other particles.
- Soft, granular drafting powder is available that provides a temporary protective coating over drawings during drafting, picks up pencil lead dust, and keeps the drawing surface clean. If used too heavily, the powder can cause lines to skip, so use sparingly, if at all.
- Pounce powder may be used to prepare drawing surfaces for inking.

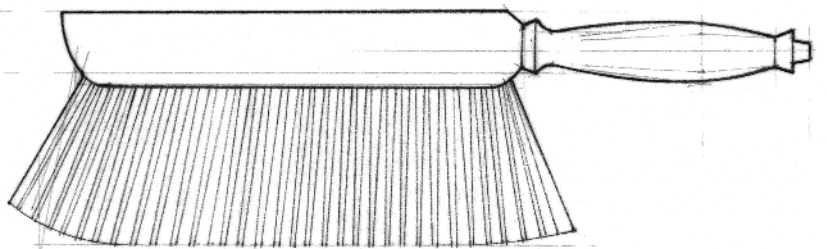

DRAWING SCALES

In drawing, "scale" refers to a proportion determining the relation of a representation to the full size of that which is represented. The term also applies to any of various instruments having one or more sets of precisely graduated and numbered spaces for measuring, reading, or transferring dimensions and distances in a drawing.

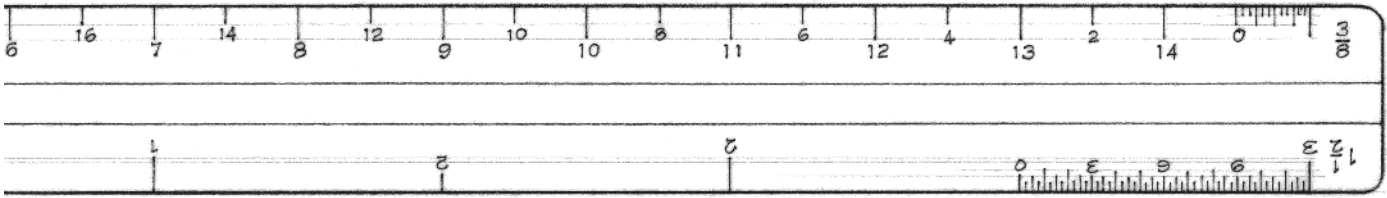

Architect's Scales

An architect's scale has graduations along its edges so that scale drawings can be measured directly in feet and inches.

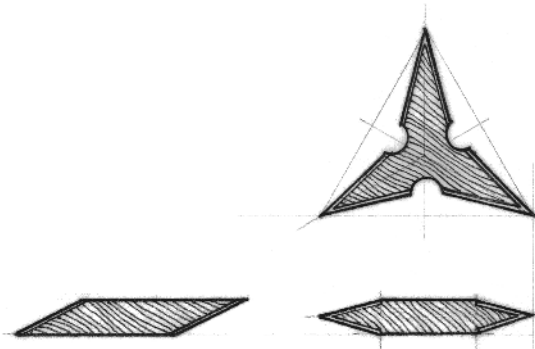

- Triangular scales have 6 sides with 11 scales, a full-size scale in $\frac{1}{16}$ " increment, as well as the following architectural scales: $\frac{3}{32}$ ", $\frac{3}{16}$ ", $\frac{1}{8}$ ", $\frac{1}{4}$ ", $\frac{1}{2}$ ", $\frac{3}{8}$ ", $\frac{3}{4}$ ", 1", $1\frac{1}{2}$ ", and 3" = 1'-0".

- Flat-beveled scales have either 2 sides with 4 scales or 4 sides with 8 scales.

- Both 12" and 6" lengths are available.
- Scales should have precisely calibrated graduations and engraved, wear-resistant markings.
- Scales should never be used as a straightedge for drawing lines.

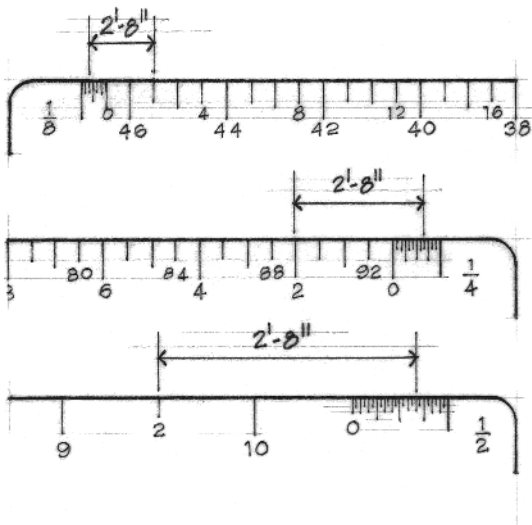

• $\frac{1}{8}$ " = 1'-0"

• $\frac{1}{4}$ " = 1'-0"

• $\frac{1}{2}$ " = 1'-0"

• To read an architect's scale, use the part of scale graduated in whole feet and the division of a foot for increments smaller than a foot.

- The larger the scale of a drawing, the more information it can and should contain.

Engineer's Scales

An engineer's scale has one or more sets of graduated and numbered spaces, each set being divided into 10, 20, 30, 40, 50, or 60 parts to the inch.

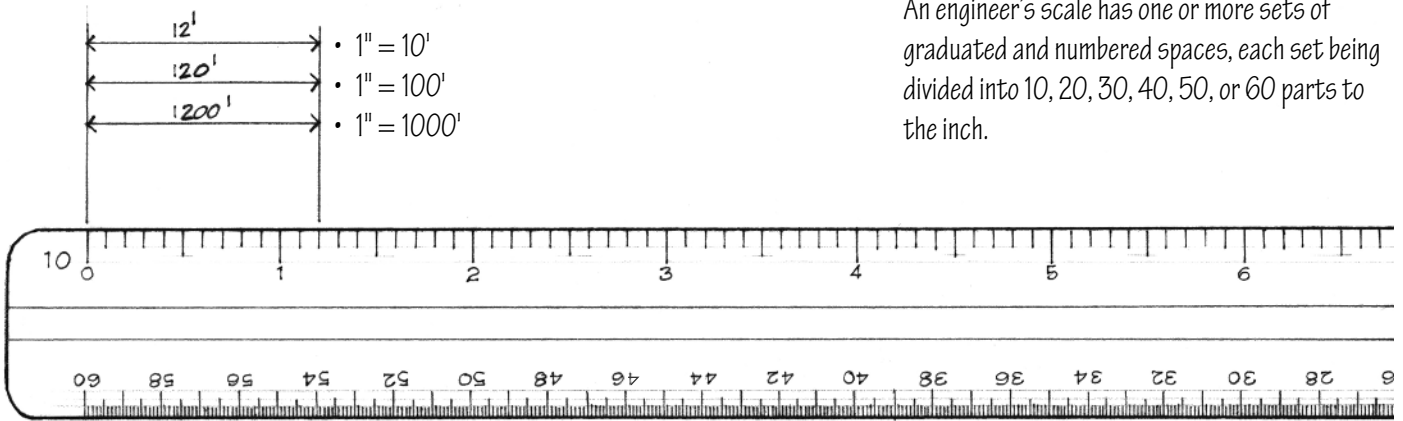

Metric Scales

Metric scales consist of one or more sets of graduated and numbered spaces, each set establishing a proportion of one millimeter to a specified number of millimeters.

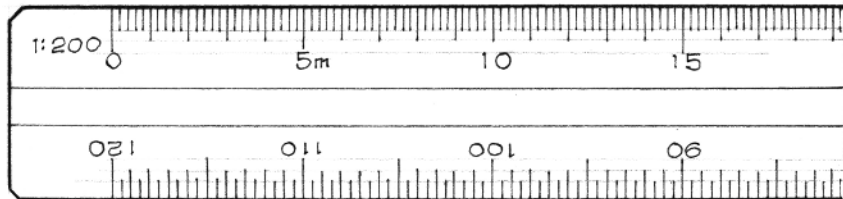

- Common metric scales include the following: 1:5, 1:50, 1:500, 1:10, 1:100, 1:1000, 1:20, and 1:200

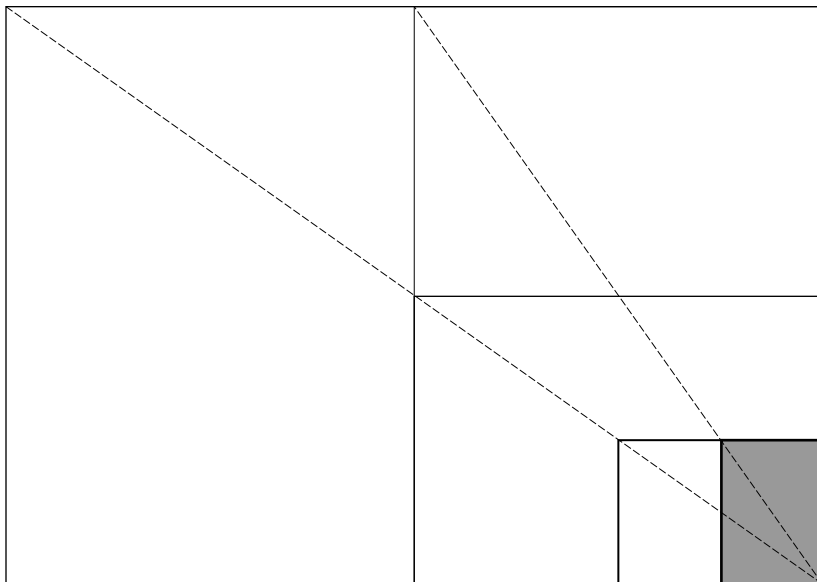

Digital Scale

In traditional drawing, we think in real-world units and use scale to reduce the drawing to a manageable size. In digital drawing, we actually input information in real-world units, but we should be careful to distinguish between the size of the image viewed on a monitor, which can be reduced and enlarged independent of its real-world size, and the scale of the output from a printer or plotter.

DRAWING SURFACES

The transparency of tracing papers and films makes them effective for overlay work, allowing the selective drawing or tracing on one sheet and the ability to see through to an underlying drawing.

Tracing Papers

Tracing papers are characterized by transparency, whiteness, and tooth or surface grain. Fine-tooth papers are generally better for inking, whereas medium-tooth papers are more suitable for pencil work.

Sketch-Grade Tracing Paper

- Inexpensive, lightweight tissue is available in white, cream, and yellow or buff colors in rolls 12", 18", 24", 30", and 36" wide.
- Lightweight trace is used for freehand sketching, overlays, and studies.
- Use only soft leads or markers; hard leads can tear the thin paper easily.

Vellum

- Vellum is available in rolls, pads, and individual sheets in 16, 20, and 24 lb. weights.
- Mediumweight 16 lb. vellum is used for general layouts and preliminary drawings.
- 16 or 20 lb. vellum with 100% rag content is a stable, translucent, and erasable paper used for finished drawings.
- Vellum is available with nonreproducible blue square grids, subdivided into 4 x 4, 5 x 5, 8 x 8, or 10 x 10 parts to the inch.
- CAD and 3D-modeling programs have the ability to organize sets of information in different layers. While these levels or categories can be thought of and used as the digital equivalent of tracing paper, they offer more possibilities for manipulating and editing the information they contain than do the physical layers of tracing paper. And once entered and stored, digital information is easier to copy, transfer, and share than traditional drawings.

Drafting Film

Drafting film is a clear polyester film that is durable, dimensionally stable, and translucent enough for clear reproductions and overlay work.

- Drafting film is 3 to 4 mil thick and available in rolls or cut sheets.
- One or both sides may have a nonglare, matte finish suitable for pencil or ink.
- Use only with compatible leads, inks, and erasers.
- Ink lines are removable with erasing fluid or a vinyl eraser saturated with erasing fluid.

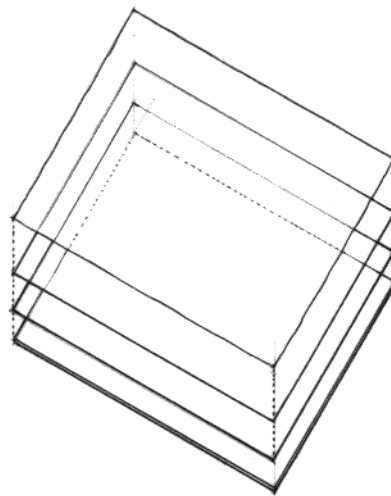

- Drafting tape or dots are required to fix a sheet of vellum or film to the drawing board. Do not use normal masking tape, which can tear the paper surface upon removal.

Illustration Boards

Illustration boards have a paper facing laminated to a cardboard backing.

- Illustration boards are available in single ($1/16$ " thick) and double ($3/32$ " thick) thicknesses.
- 100% rag paper facings are recommended for finish presentations.
- Coldpress boards have a degree of texture for pencil work; hotpress boards have relatively smooth surfaces more suitable for inking.
- Some brands of illustration boards have white facing papers bonded to a middle core of white stock. Cut edges are therefore consistently white in color, making them useful for constructing architectural models.
- The opacity of illustration boards requires that drawings be laid out directly on the board surface.

The following may be used to cover drawing boards:

- Vinyl covers provide a smooth, even drawing surface; tack holes and cuts heal themselves.
- Cellulose acetate film laminated to a tough paper base provides a smooth, nonglare surface.
- A dense, white illustration board provides an inexpensive drawing surface.