

Contents

Forewords viii

Introduction x

PART I ■ CREATING A CHARACTER WITH BLENDER 1

Chapter 1 ■ Blender Basics: Interface and Objects 3

Work Areas and Window Types 4

Navigating the 3D Space 9

Objects and Datablocks 18

User Preferences 24

Chapter 2 ■ Working with Meshes 27

Polygons and Subsurfacing 28

Extrusion Modeling and Box Modeling 32

Chapter 3 ■ Completing the Model with Materials, Textures, and Particles 89

Material Datablock 90

Material Properties 92

Textures and UV Mapping 99

Using Static Particles 116

Chapter 4 ■ Armatures and Rigging 129

Blender Armature System 130

Building a Simple Armature 131

Rigging Captain Blender 141

Chapter 5 ■ Shape Keys and Facial Rigging 187

Shape Key Basics 188

Building a Shape Key Set for Captain Blender 198

Facial Bones and Controls 217

Improved Mesh Deformations Using Driven Shape Keys 234

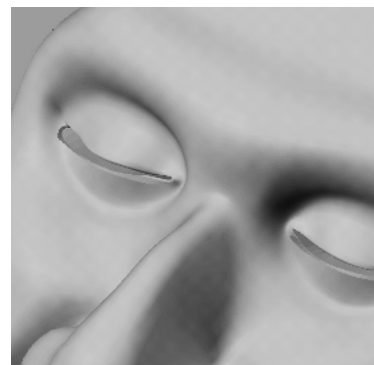
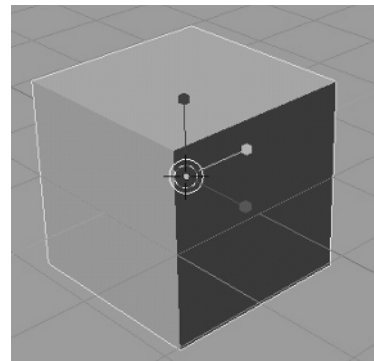
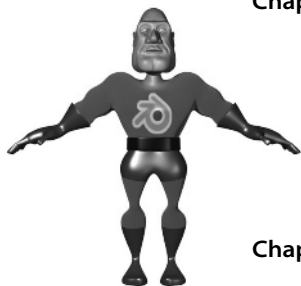

PART II ■ BRINGING IT TO LIFE: ANIMATION 239

Chapter 6 ■ Basics of Animation 241

Keyframes and Ipos 242

Using the Ipo Editor: Bouncing a Ball 244

Interpolation and Extend Types 252

Chapter 7 ■ Armature Animation 259

Posing and Keyframing with the
Action Editor 260

Walk and Run Cycles 273

Pose-to-Pose Animation 288

Chapter 8 ■ Facial Animation and Lip Sync 299

Facial Posing 300

Lip Sync 306

Playback 312

Chapter 9 ■ Nonlinear Animation 315

Using the NLA Editor 316

NLA in Action 325

Mixing Actions: Walking and Talking 337

**Chapter 10 ■ Further Issues in
Character Animation 341**

Interacting with Props 342

Deformation with Lattices 350

Softbodies and Metaballs 356

**Chapter 11 ■ Lighting, Rendering, and
Editing Your Animation 363**

Lighting Basics 364

Rendering Your Animation 379

Editing in the Sequence Editor 383

Chapter 12 ■ Using Python Scripts 387

Installing and Executing Python Scripts 388

Standard Scripts 389

Extended Functionality with Scripts 396

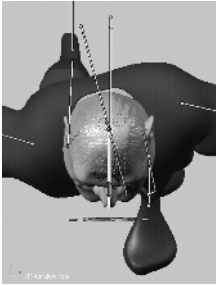

PART III ■ BLENDER IN PRODUCTION 399

**Chapter 13 ■ Full-Scale Productions:
Elephants Dream and Plumiferos 401**

GPL, Creative Commons, and the
Blender Artistic License 402

Elephants Dream, the World’s First
“Open Movie” 403

A Preview of Plumiferos 405

Chapter 14 ■ A Look Into Elephants Dream 407

Proog and Emo Rigs 408

Texturing Proog 421

Ways of Walking: Following a Path vs.
a Manually Keyed Walk 422

Tips on Studying the Elephants Dream Files 424

**Chapter 15 ■ Feifi the Canary: Plumiferos
Takes Wing 427**

Introducing Feifi 428

Rigging a Cartoon Bird 432

Chapter 16 ■ Blender in the Pipeline 441

Production Pipeline 442

Using Libraries 445

Collaboration with Subversion and Verse 445

...and Back Into Blender 446

PART IV ■ BLENDER AND BEYOND 449

Chapter 17 ■ Other Software and Formats 451

Importing and Exporting Other
File Formats 452

Useful Open-Source Software for
Blender Artists 453

Blending into the (Near) Future 457

Chapter 18 ■ Resources for Further Learning 459

Selected Online Resources 460

Recommended Books 464

On Becoming a Blender Master 466

Index 467

